

INTENDED FOR USE BY PROFESSIONAL EQUIPMENT OPERATORS

OPERATING INSTRUCTIONS



908 W. Main • P.O. Box 368
Laurel, MT USA 59044
(1) 800-548-7341
(1) 406-628-8231
www.wpg.com

 **READ AND UNDERSTAND BEFORE
OPERATING THIS EQUIPMENT**

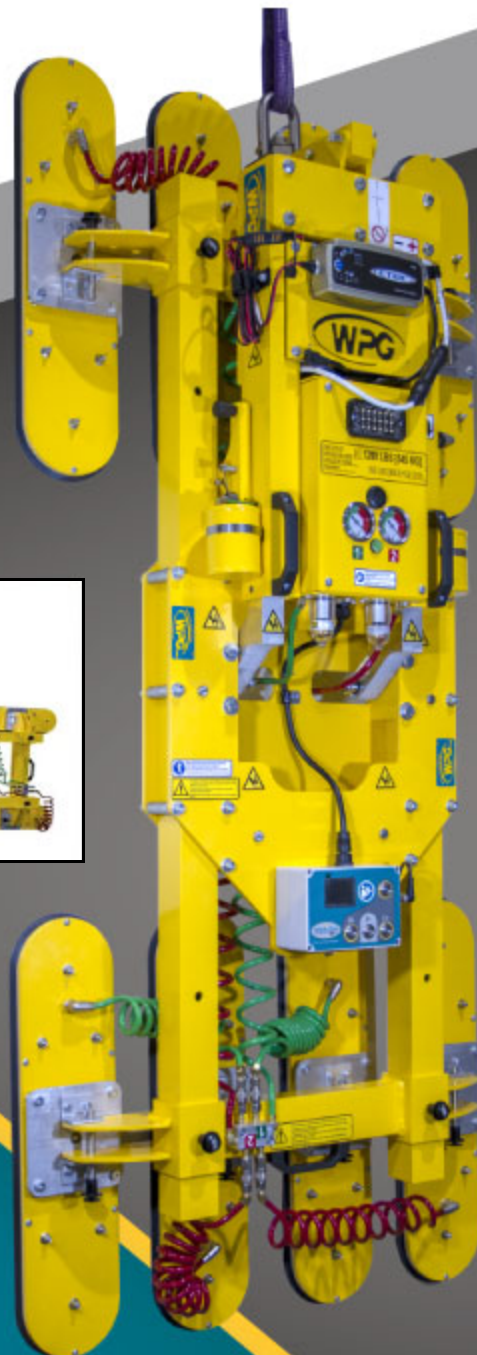
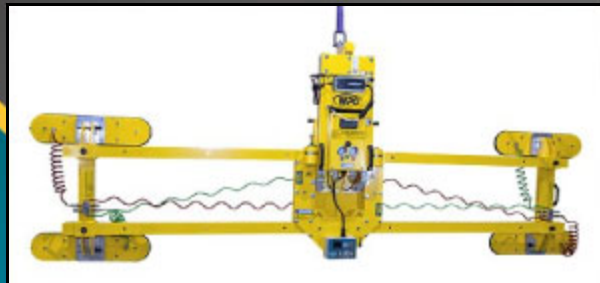

**MANUAL FILTER,
DC-VOLTAGE WITH
INTELLI-GRIP® TECHNOLOGY**
(Available with REMOTE CONTROL SYSTEM)

Model numbers: MTEX4625DC3,
MTEX8625DC3 (shown)

Original Instructions © Wood's Powr-Grip Co., Inc.







TABLE OF CONTENTS

SPECIFICATIONS	3
SAFETY	5
OPERATING FEATURES	6
MTEX-DC3 FEATURES.....	6
INTELLI-GRIP® CONTROL UNIT FEATURES	7
ASSEMBLY	8
TO CHANGE THE PAD FRAME CONFIGURATION	10
Repositioning (or Removing) Movable Pad Mounts	12
Repositioning (or Removing) the Sliding Pad Arms.....	13
Removing and Installing Pad Frame Tubes.....	14
Connecting/Disconnecting Vacuum Hoses	19
TO INSTALL THE OPTIONAL ROOF PANEL KIT	20
INTENDED USE	26
LOAD CHARACTERISTICS.....	26
ALLOWABLE OVERHANG	27
INDIRECT LOADING	27
OPERATING ENVIRONMENT	28
DISPOSAL OF THE LIFTER	28
OPERATION	29
BEFORE USING THE LIFTER.....	29
Taking Safety Precautions	29
Selecting a Screen Language.....	29
Performing Inspections and Tests	30
Checking the 12-Volt Battery	30
Preparing to Use the Remote Control System	31
TO ATTACH THE PADS TO A LOAD	32
Positioning the Lifter on the Load.....	32
Powering up the Lifter	34
Sealing the Pads on the Load.....	34
Reading the Vacuum Gauges	35
TO LIFT AND MOVE THE LOAD.....	36
Interpreting the Lift Light.....	36
Monitoring Vacuum Indicators	36

TABLE OF CONTENTS

Controlling the Lifter and Load	37
In Case of a Power Failure	37
TO TILT THE LOAD	38
Tilting Loads When Lifter is Positioned “Above Center”	38
Tilting Loads When Lifter is Positioned “On Center”	39
Operating the Tilt Latch	39
TO RELEASE THE PADS FROM THE LOAD	41
AFTER USING THE LIFTER.....	42
Storing the Lifter	42
Transporting the Lifter	43
INSPECTIONS AND TESTS.....	44
INSPECTION SCHEDULE	44
TESTING	45
Lifter/Load Compatibility Test.....	45
Operational Tests	46
Vacuum Test.....	46
Rated Load Test.....	47
Remote Control System Test	47
MAINTENANCE	48
VACUUM PAD MAINTENANCE.....	48
Pad-to-Load Friction Coefficient	48
Pad Inspection	48
Pad Cleaning	49
TO REPLACE PAD INSERTS IN VPFS625 PADS	50
12-VOLT BATTERY RECHARGE.....	52
NOTIFICATION BUZZER BATTERY REPLACEMENT	53
INTELLI-GRIP® DIAGNOSTIC CODES	54
REPLACEMENT PARTS.....	58
REGISTRATION AND LIMITED WARRANTY	59
TO REGISTER THIS WPG PRODUCT	59
ABOUT THE LIMITED WARRANTY	59
Obtaining Warranty Service or Repair Service.....	59

SPECIFICATIONS

Product Description	Designed for use with hoisting equipment, MTEX-DC3 lifters support loads using vacuum and manipulate loads using manual 90° tilt motions.	
Model Number	MTEX8625DC3	MTEX4625DC3
Vacuum Pads¹	Eight with nominal dimensions of 6" x 25" [15 cm x 64 cm] (Model VPFS625)	Four with nominal dimensions of 6" x 25" [15 cm x 64 cm] (Model VPFS625)
Maximum Pad Spread (to outer edges)	76" x 34" [193 cm x 86 cm] in vertical configurations 135¾" x 34" [345 cm x 86 cm] in horizontal configurations 254¾" x 34" [647 cm x 86 cm] with optional Pad Frame Extension Kit installed	
 Maximum Load Capacity^{2, 3}	Per pad: 150 lbs [68 kg] Total: 1200 lbs [545 kg]	Per pad: 150 lbs [68 kg] Total: 600 lbs [270 kg]
 Lifter Weight		
Lifter only	315 lbs [143 kg]	275 lbs [125 kg]
w/ optional Pad Frame Extension Kit installed	450 lbs [205 kg]	410 lbs [186 kg]
Power Source	12 volts DC, 5.5 amps	
Battery Capacity	18 amp-hours	
 Tilt Capability	Manual, 90°, with automatic latching in the upright position	
 Product Options	<i>Available</i> with Remote Control System – FCC, CE, IC, RSM and ACMA compliant ⁴ <i>Available</i> with Pad Frame Extension Kit (for roof panel installation) See separate instructions about other options.	
 Operating Elevation	Up to 6,000' [1,828 m]	
 Operating Temperatures	32° – 104° F [0° – 40° C]	
Service Life	16,000 lifting cycles, when used and maintained as intended ⁵	
ASME Standard BTH-1	Design Category "B", Service Class "0"	
Troubleshooting Guide	TST-016_GENERIC_LEAK_TEST_rev_2014-086	

- 1..... Standard with replaceable pad inserts for rough or textured surfaces (see ["REPLACEMENT PARTS"](#)).
- 2..... The Maximum Load Capacity is rated and verified at a vacuum of 16" Hg [-54 kPa] on clean, smooth, nonporous flat surfaces with a friction coefficient of 1. Rating is verified by testing on polycarbonate (or metal with a painted surface) with a coefficient of friction similar to plain (non-coated) glass and a surface temperature at approx. 70° F [21° C].
- 3..... Pad compound, load rigidity, strength, surface conditions, overhang, angle, center of gravity and temperature affect lifting capacity. A "qualified person" should evaluate the effective lifting capacity for each use (see definition under ["Rated Load Test"](#)).
- 4..... "RSM and ACMA compliant" means that the remote control system is eligible for the Regulatory Compliance Mark (RCM).
- 5..... Vacuum pads, filter elements and other wear-out items are excluded.

SPECIFICATIONS

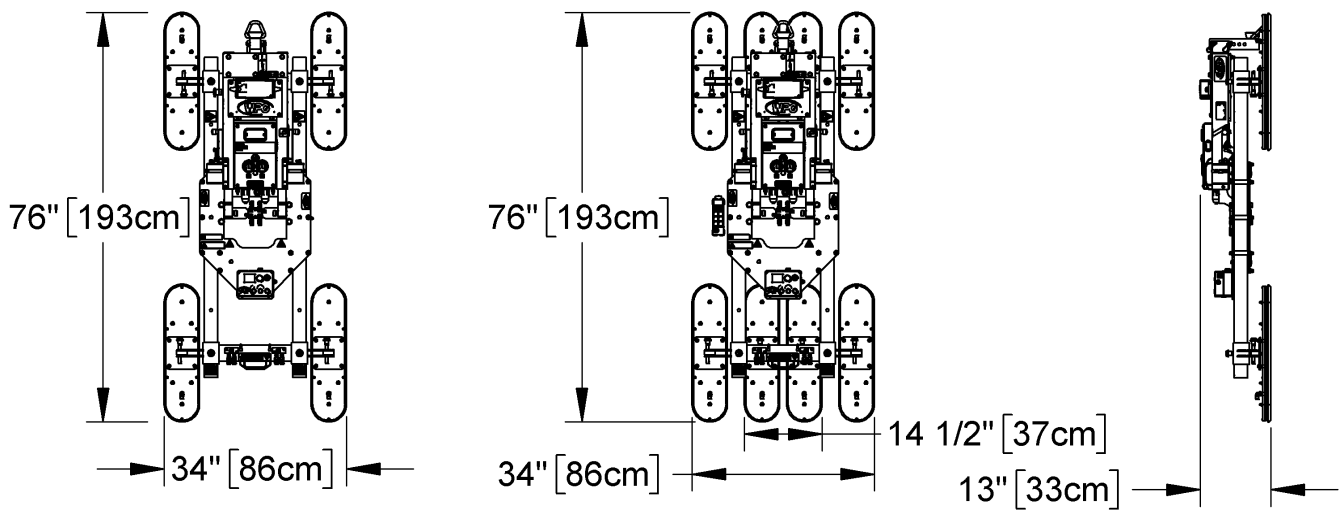

Note: Drawings show vertical orientation only.

SAFETY



Wear personal protective equipment that is appropriate for the load material. Follow trade association guidelines.



Do not remove or obscure safety labels.



Do not make any modifications to the lifter. Modifying the lifter will void the "LIMITED WARRANTY".



Use the lifter only in an approved "OPERATING ENVIRONMENT" (see "INTENDED USE").



Make sure to consider all possible effects of "INDIRECT LOADING" on lifting capacity (see "INTENDED USE").



Do not use a lifter that is damaged, malfunctioning, or missing parts.



Do not use a lifter if the sealing edge of any vacuum pad is cut or otherwise damaged.



Do not use a lifter to lift cracked or broken glass.



Do not exceed the Maximum Load Capacity or lift loads the lifter is not designed for (see "INTENDED USE").



Do not use a lifter if the Maximum Load Capacity or any safety label appears to be missing or obscured.



Make sure the contact surfaces of the load and vacuum pads are clean before attaching the lifter (see "MAINTENANCE").



Position the vacuum pads correctly on the load before lifting (see "OPERATION").



Do not lift a load if any vacuum indicator shows inadequate vacuum.



Keep unauthorized personnel away from the lifter, to avoid injury in case of an unintended load release.



Do not touch the vacuum release controls during a lift.



Do not allow people to ride on the lifter or the load.



Do not lift a load higher than necessary or leave suspended loads unattended.



Do not position a loaded or unloaded lifter over people.



Before servicing a powered lifter, place the power control in the inactive position and, when possible, disconnect the power source.

OPERATING FEATURES

Features shown here are underlined> on their first appearance in each section following.

MTEX-DC3 FEATURES

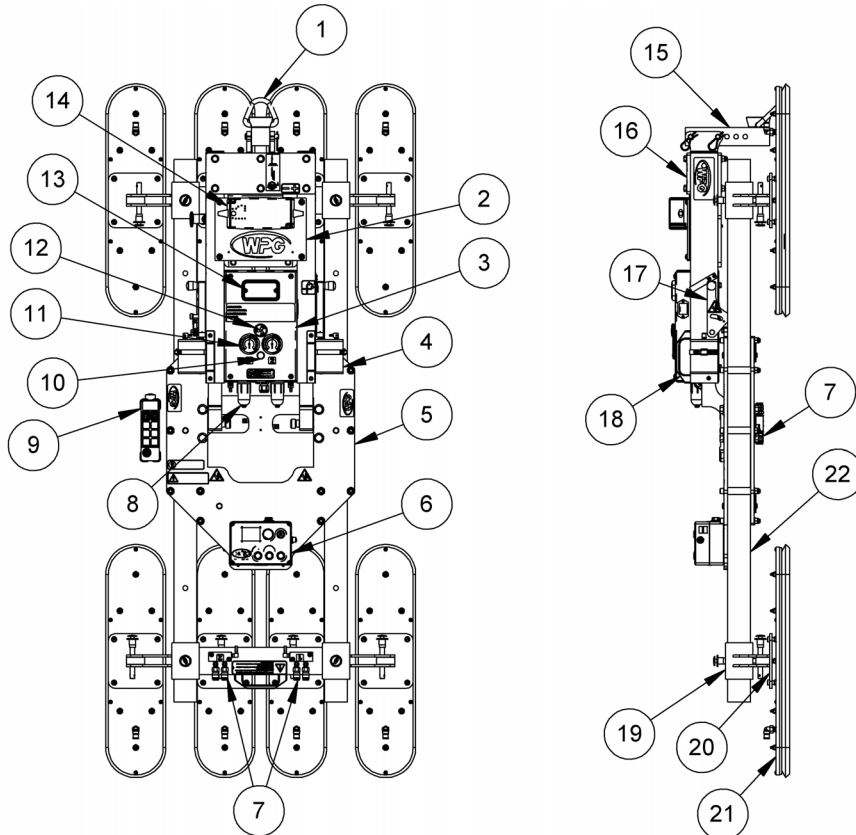

- | | | | | | |
|----|-----------------------|----|--------------------------------|----|---|
| 1 | LIFT POINT | 2 | Cover for BATTERY | 3 | Enclosure w/ VACUUM PUMP and VACUUM SENSORS |
| 4 | VACUUM RESERVE TANK | 5 | PAD FRAME | 6 | INTELLI-GRIP® CONTROL UNIT |
| 7 | QUICK CONNECTORS | 8 | AIR FILTER | 9 | RADIO TRANSMITTER (option) |
| 10 | VACUUM LIFT LIGHT | 11 | VACUUM GAUGE | 12 | NOTIFICATION BUZZER |
| 13 | STROBE LIGHT | 14 | BATTERY CHARGER | 15 | ADJUSTABLE LIFT POINT MOUNT |
| 16 | LIFT BAR | 17 | CONTROL LEVERS for TILT LATCH | 18 | CONTROL HANDLE |
| 19 | SLIDING PAD ARM | 20 | MOVABLE PAD MOUNT | 21 | VACUUM PAD |
| 22 | FEMALE PAD FRAME TUBE | | Not shown: MALE PAD FRAME TUBE | | |

Notes: A standard MTEX8625DC3 is shown; the standard MTEX4625DC3 has identical features. Although some of the following photos do not show this specific lifter, they all illustrate how this kind of lifter functions.

For information about specific parts, see [“REPLACEMENT PARTS”](#) and/or any separate instructions for Product Options.

OPERATING FEATURES

INTELLI-GRIP® CONTROL UNIT FEATURES

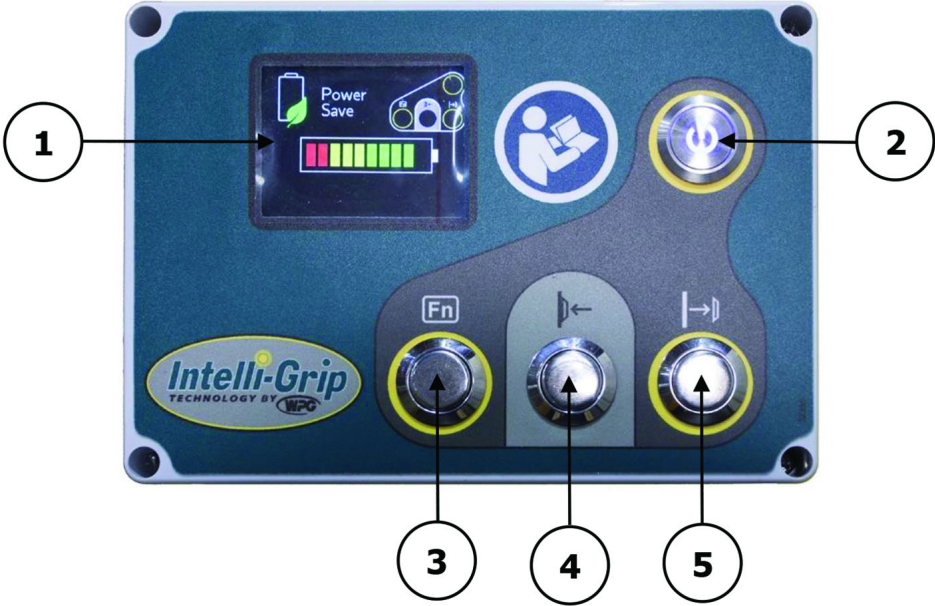

- 1 LCD SCREEN WITH BATTERY GAUGE
- 2 "POWER" BUTTON
- 3 "FUNCTION" BUTTON
- 4 "ATTACH" BUTTON
- 5 "RELEASE" BUTTON

ASSEMBLY

- 1) Remove all shipping materials and save them with the shipping container for future use.
- 2) Position the adjustable lift point mount (fig. 2A) to optimize the hang angle of the lifter and load:

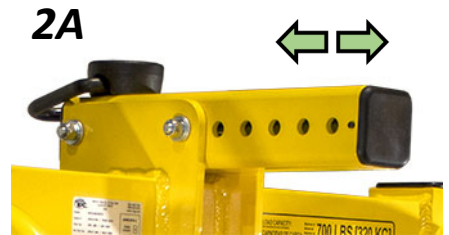

- 2.1) Remove both retaining bolts.
- 2.2) Reposition the adjustable tube as needed.
- 2.3) Reinstall the retaining bolts and tighten them securely.

- 3) Suspend the lifter from appropriate hoisting equipment:

- 3.1) Select a crane and/or hoist rated for the Maximum Load Capacity plus the Lifter Weight.

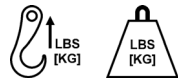

Note: Any lifter use must comply with all statutory or regulatory standards for hoisting equipment in your region.

- 3.2) Disengage the tilt latch (see “[Operating the Tilt Latch](#)”) and raise the lift bar (fig. 3A).

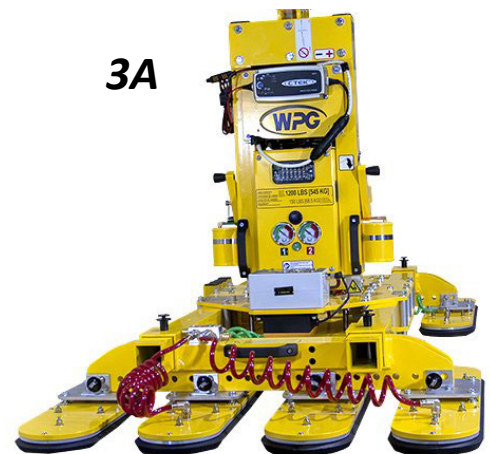

- 3.3) Attach the hoisting hook to the lift point (fig. 3B).

 **Make sure hook has restraining latch (arrow in fig. 3A).**

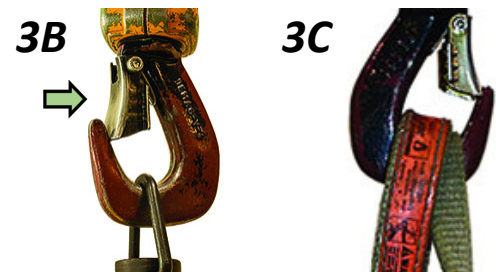

Note: Use rigging (fig. 3C) as needed to make sure the hook does not interfere with the load.

 **Only use rigging rated for Maximum Load Capacity plus Lifter Weight.**

- 4) Use the hoisting equipment to remove the lifter from the shipping container. Avoid damaging the vacuum pads.

ASSEMBLY

- 5) Connect the electrical connectors (figs. 5B-C and 5D-E.)

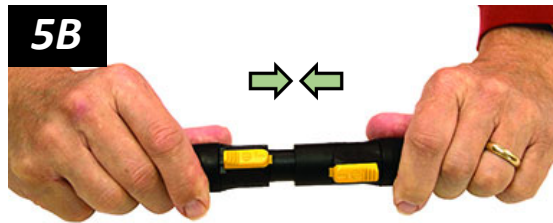

Note: Make sure the AC plug for the battery charger is connected, as well (figs. 5F-G).



- 6) Install the 9-volt battery for the notification buzzer as directed in the “[NOTIFICATION BUZZER BATTERY REPLACEMENT](#)”.
- 7) Assemble the pad frame for optimal load support (see “[TO CHANGE THE PAD FRAME CONFIGURATION](#)”).
- 8) Remove the pad covers and save them for future use (fig. 8A).

8A



- 9) Perform tests as required under “[TESTING](#)”.

ASSEMBLY

TO CHANGE THE PAD FRAME CONFIGURATION

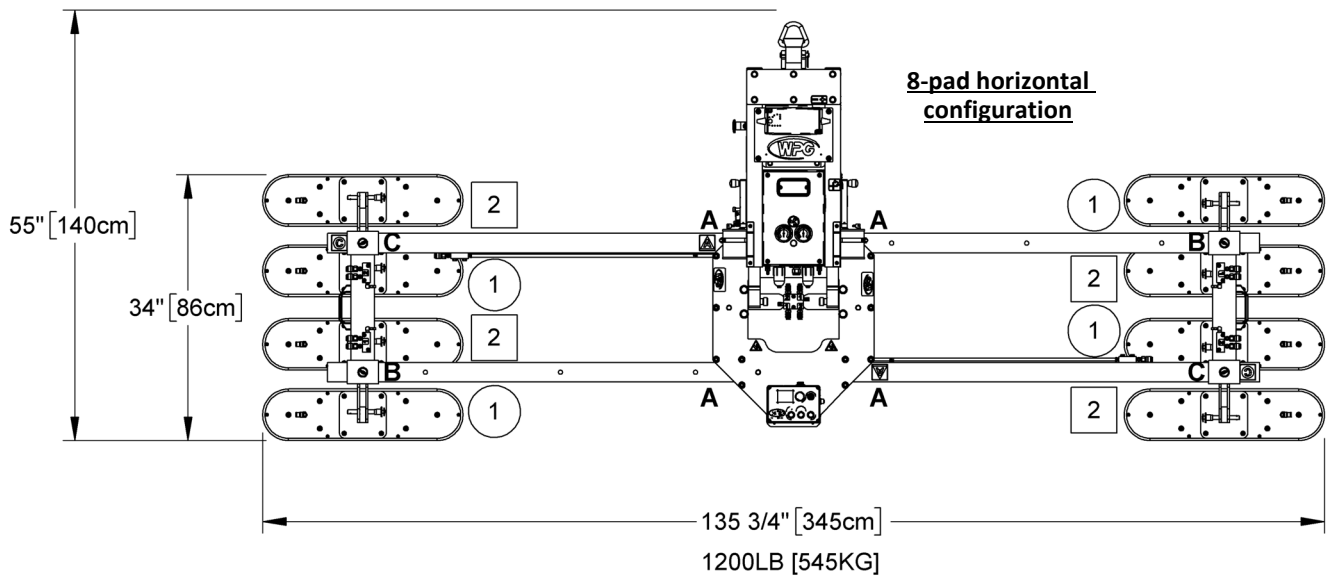
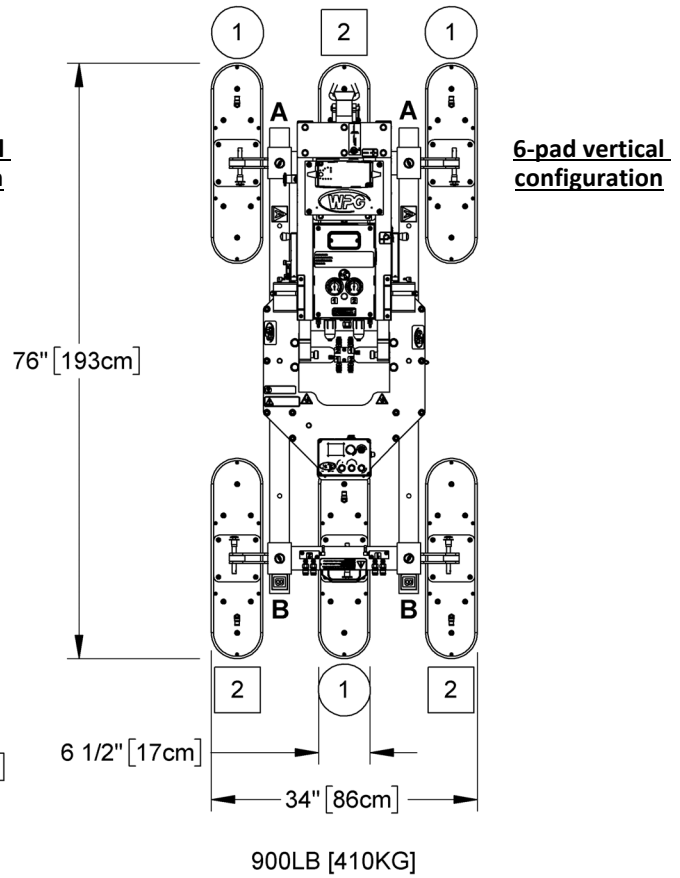
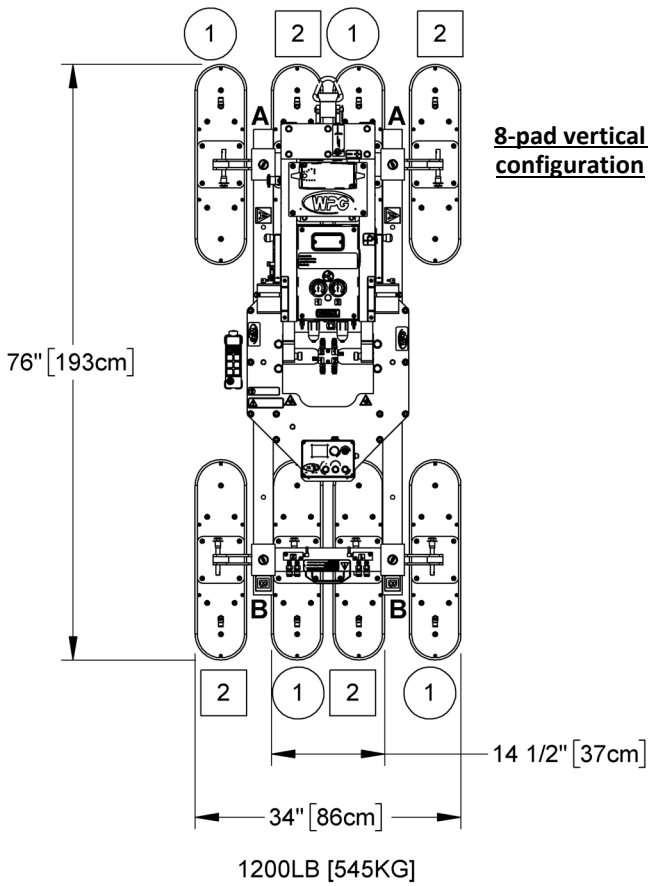

ASSEMBLY

Various pad frame configurations enable the lifter to match different load dimensions, weights, and orientations.

On the preceding page, the 2 illustrations at the top show maximum pad spreads when the pad frame is configured for handling vertically oriented panels (ie, vertical configurations), while the illustration at the bottom shows the maximum pad spread when the pad frame is configured for handling horizontally oriented panels (ie, horizontal configurations). Other configurations are also possible. For more information, see [“Positioning the Lifter on the Load”](#).

When configuring the pad frame, pads must be arranged symmetrically.



Make sure all pads are parallel to one another and arranged symmetrically, to avoid accidental load release.

Each pad frame tube is coded with an “A”, “B” or “C” sticker. Make sure to configure the pad frame according to the alphabetic code shown in the illustrations.

Caution: Connect the vacuum pads to the 2 circuits of the dual vacuum system (marked “1” and “2” in the preceding illustrations).

- 1) Choose a configuration that maximizes support across the load surface and minimizes load overhang (see [“LOAD CHARACTERISTICS”](#)).
- 2) Reposition the sliding pad arms, movable pad mounts and pad frame tubes, as needed:
 - To support larger load dimensions, you must move pad mounts and pad arms outward (see [“Repositioning \(or Removing\) the Sliding Pad Arms”](#) and [“Repositioning \(or Removing\) Movable Pad Mounts”](#)).
 - To support longer load dimensions, you must configure the pad frame in the horizontal orientation (see [“Removing and Installing Pad Frame Tubes”](#)).
 - To support the maximum load weight, you must connect all 8 vacuum pads (see [“Connecting/Disconnecting Vacuum Hoses”](#)).
 - To support smaller load dimensions and weights, you may move pad arms and pad mounts inward, and/or disconnect vacuum hoses, **provided the lifter still has sufficient capacity to support the load in question.**¹



Disconnecting any vacuum pad reduces lifting capacity.

1..... Whenever a quick connector is disconnected, the corresponding vacuum pad does not contribute to the lifting capacity, whether or not the pad is mounted on the pad frame.

ASSEMBLY

Moving the pad frame from the upright position to the flat position, and vice versa, is necessary to complete ASSEMBLY procedures. See “[TO TILT THE LOAD](#)” before proceeding.

*Note: The tilt latch does **not** engage in the fully flat position.*

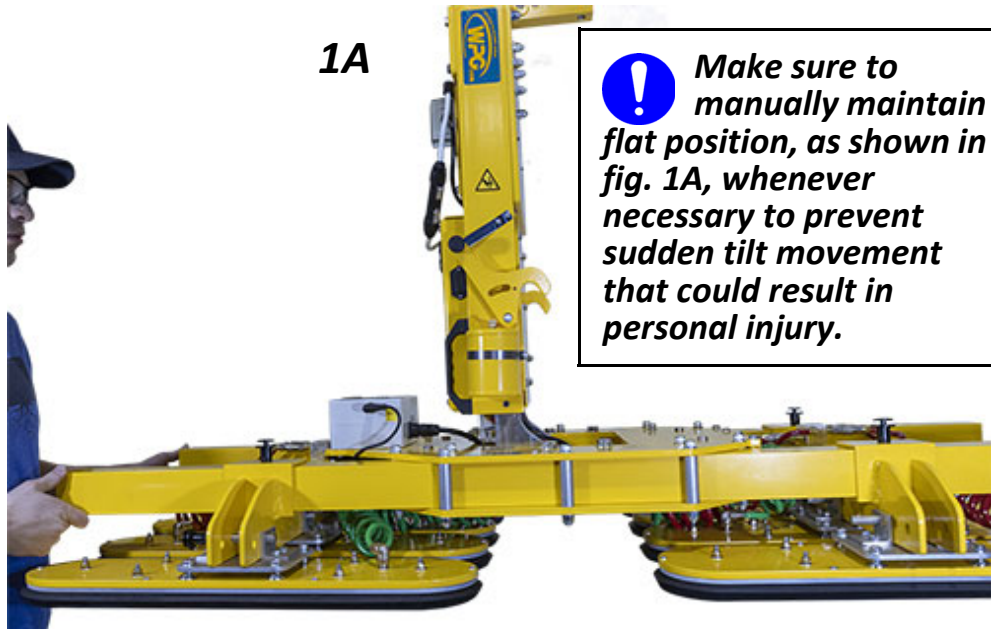

Repositioning (or Removing) Movable Pad Mounts

- 1) Make sure the pad frame is in the upright position and the tilt latch is engaged.
- 2) Remove the cotterless hitch pin that secures a movable pad mount to the sliding pad arm (fig. 2A).
- 3) Move the pad mount to the desired position on the pad arm (fig. 3A), aligning the pin holes.

Note: Each pad mount has 2 pin holes (circled in fig. 3A) for more precise positioning.

Alternatively, you may remove the pad mount. Store the removed mount with its pin in a clean, dry location.

Note: When you set the pad mounts aside, make sure to place protective spacers under the vacuum pads.¹

- 4) Reinsert the pin, to secure the pad mount.
- 5) Repeat steps 2-4 with the other similarly positioned pad mounts (outermost or innermost), to maintain symmetry.²

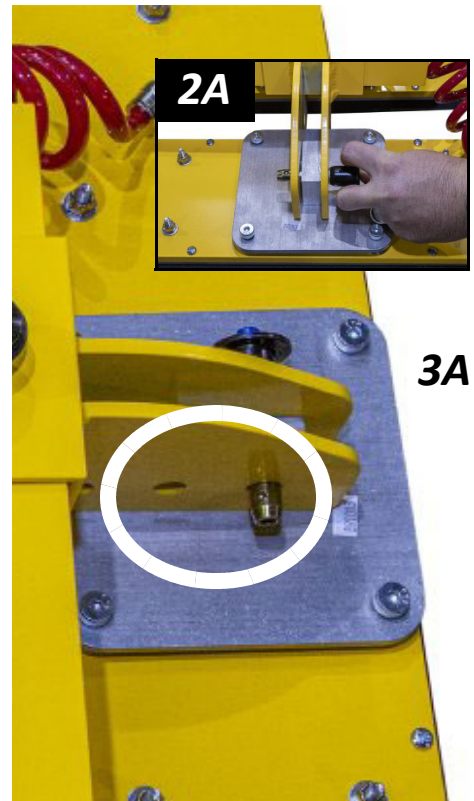

1..... Spacers are integrated into the original shipping container. Use similarly shaped spacers when setting the lifter on other surfaces.

2..... Each movable pad mount can be rotated 180° to allow for optimal hose routing.

ASSEMBLY

Repositioning (or Removing) the Sliding Pad Arms

1) Disengage the tilt latch and move the pad frame to the flat position.

2) Remove the 2 cotterless hitch pins that secure a sliding pad arm to 2 female pad frame tubes (fig. 2A).

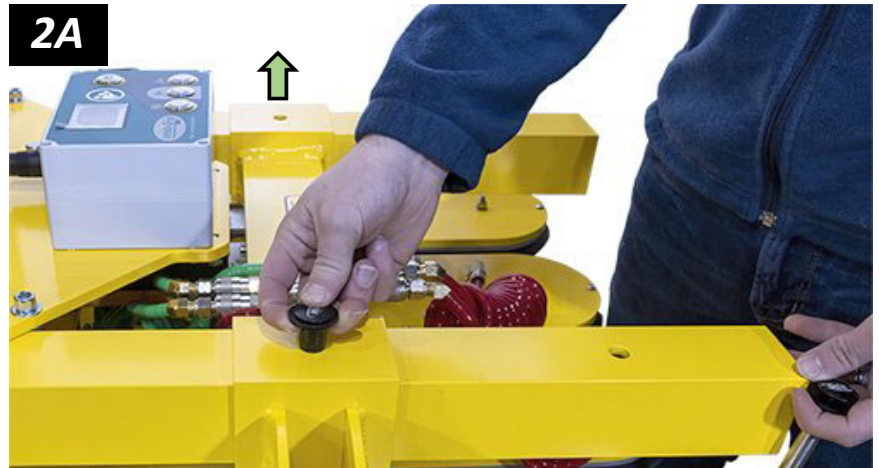

3) Move the pad arm to the desired position on the tubes (fig. 3A), aligning the pin holes.

Note: Pad arms can be fully removed, to allow removal and installation of pad frame tubes (see next page).

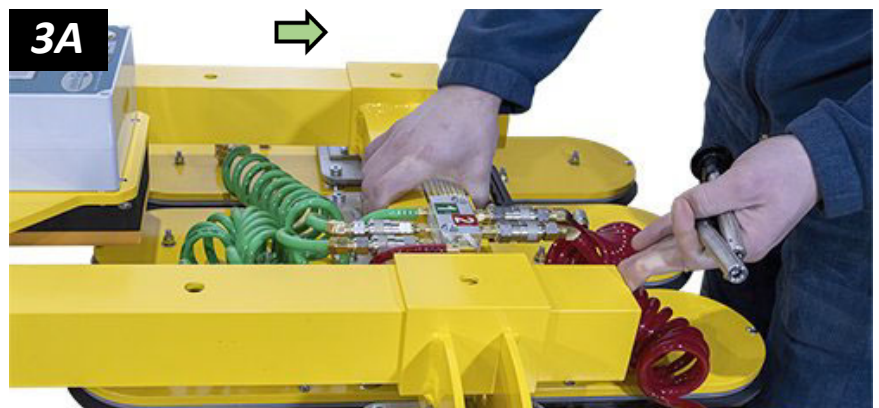

4) Reinsert the pins, to secure the pad arm (fig. 4A).

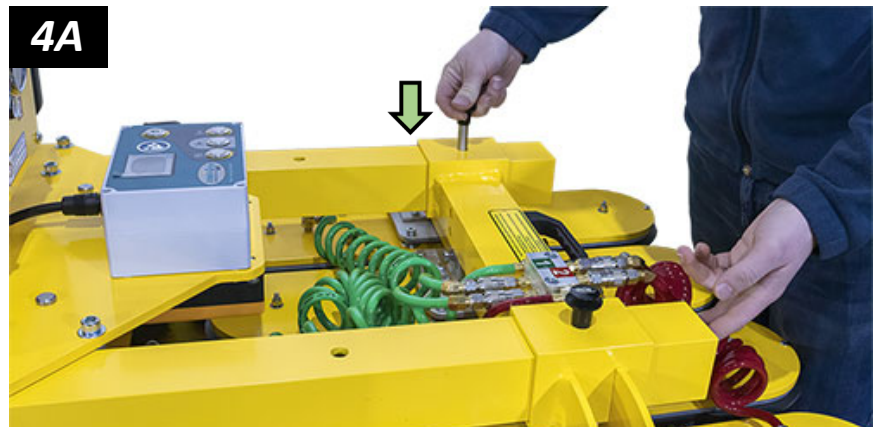

5) Repeat steps 2-4 with the other pad arm. Make sure its position on the tubes creates a symmetrical pad frame, for maintaining balance when handling a load.

ASSEMBLY

Removing and Installing Pad Frame Tubes

Note: This procedure describes a vertical-to-horizontal reconfiguration.

1) Move the pad frame to the upright position until the tilt latch engages.

2) Disconnect the vacuum hoses (figs. 2A-B; see [“Connecting/Disconnecting Vacuum Hoses”](#)).

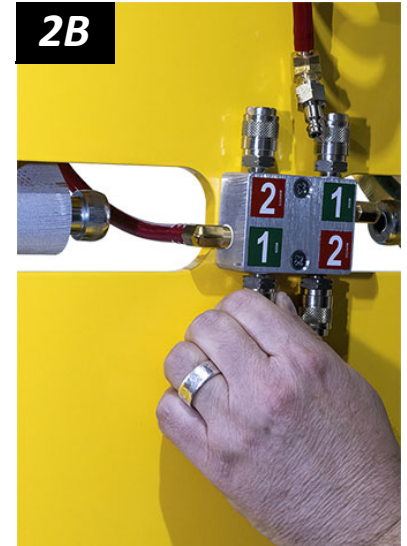
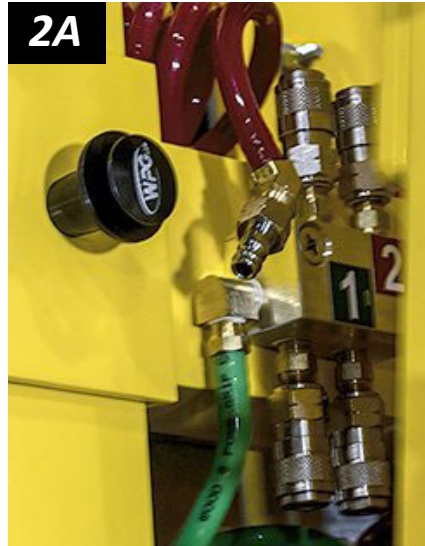

3) Remove all movable pad mounts, as previously directed, from the sliding pad arms (figs. 3A-C).



ASSEMBLY

4) Disengage the tilt latch and move the pad frame to the flat position.

5) Remove the sliding pad arms from the female pad frame tubes (figs. 5A-B).

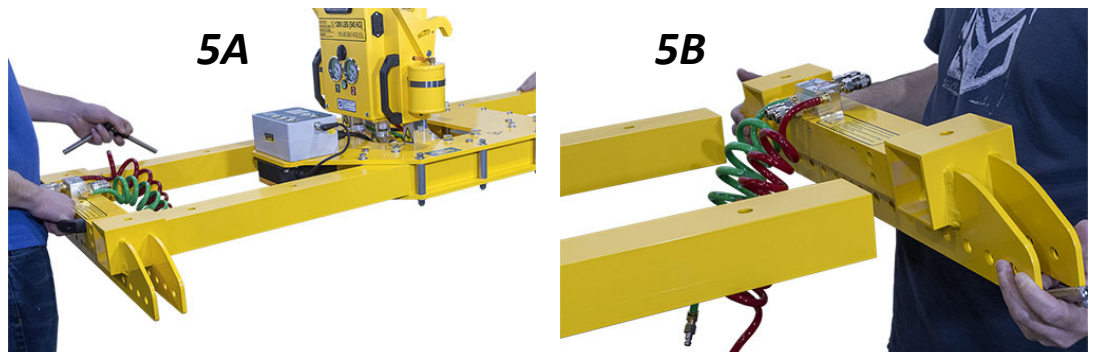

6) Move the pad frame to the upright position until the tilt latch engages.

7) Remove the pins that secure one female pad frame tube in the vertical orientation on the pad frame:

7.1) Grasp the tube, to prevent it from falling.

7.2) Remove the hitch pin from a mounting pin (fig. 7A).

7.3) Remove the mounting pin from the pad frame (fig. 7B).

7.4) Repeat steps 7.1, 7.2 and 7.3 with the other female pad frame tube.

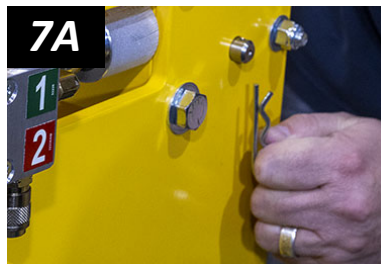

8) Slide the female pad frame tubes out of the pad frame (fig. 8A).



ASSEMBLY

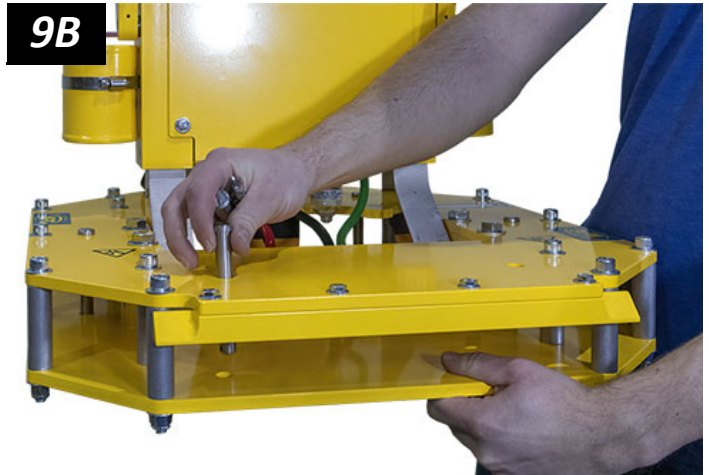

9) Similarly to step 7, remove the pins used to secure pad frame tubes in the horizontal orientation (figs. 9A-B).

Note: The pad frame can be moved to the flat position, to make it easier to remove the mounting pins, as shown in fig. 9B.

10) Install a male pad frame tube in the pad frame, as shown in fig. 10A. Align the pin holes. Then secure with pins, as previously directed (figs. 10B-C).

Note: The pad frame can be moved to the upright position, to make it easier to install hitch pins, as shown in fig. 10C.

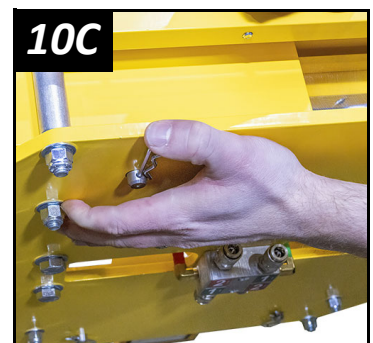
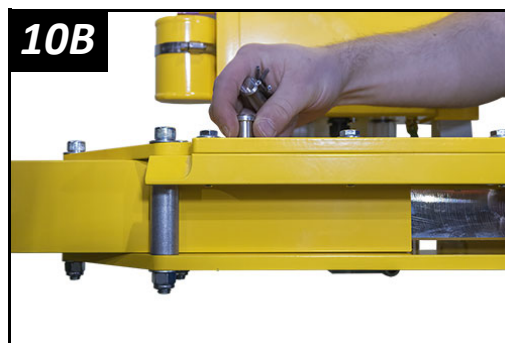
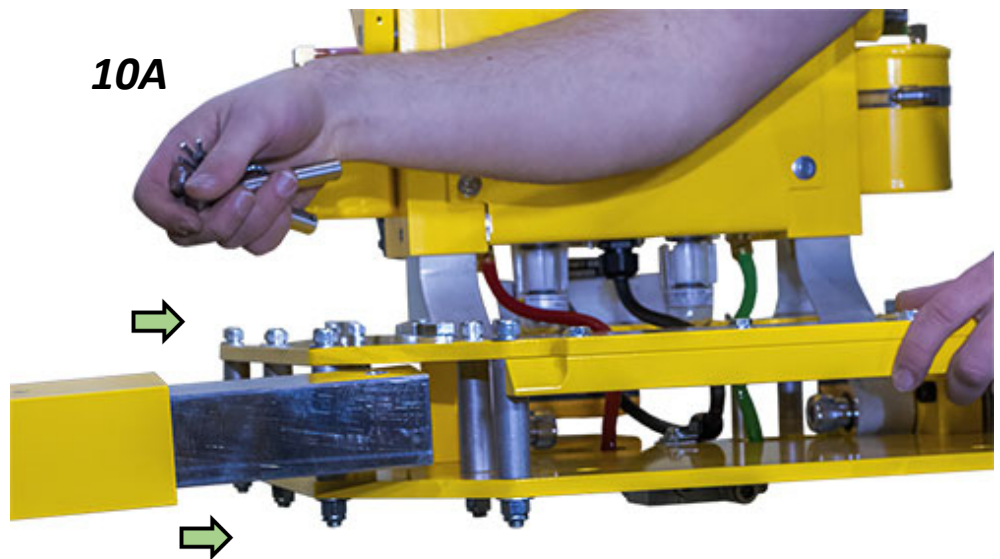

ASSEMBLY

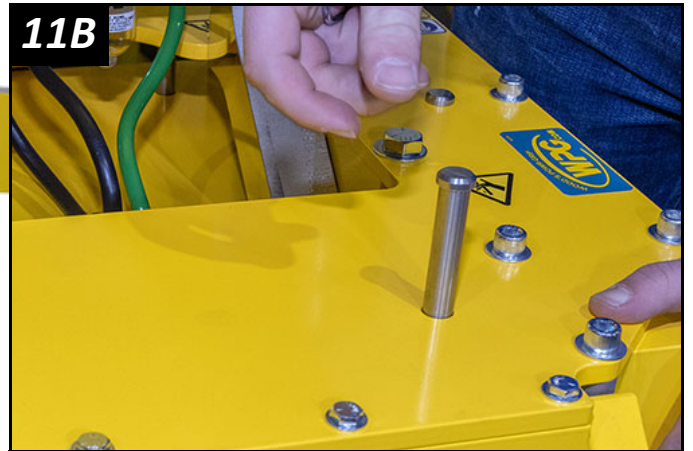
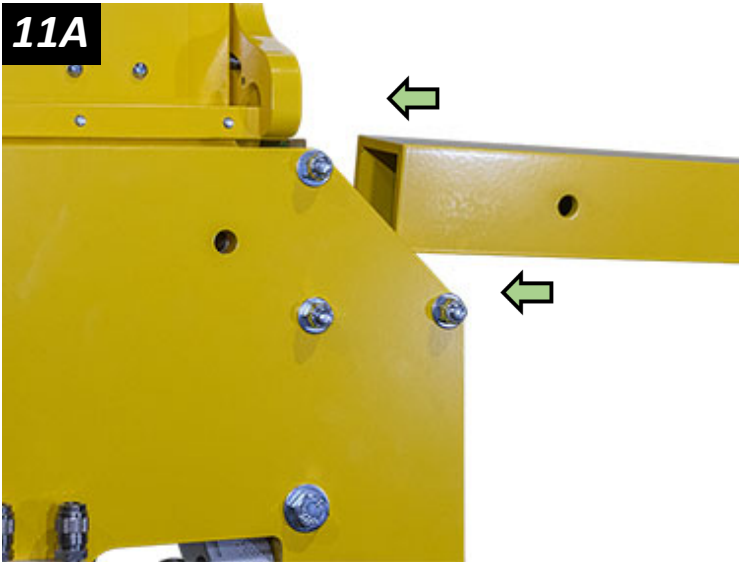

- 11) Re-install a female pad frame tube so it connects with the installed male pad frame tube (fig. 11A), making sure the pin holes align. Then secure with pins, as previously directed (fig. 11B).
- 12) Repeat steps 9 through 11 with the other connecting set of pad frame tubes (fig. 12A-B).

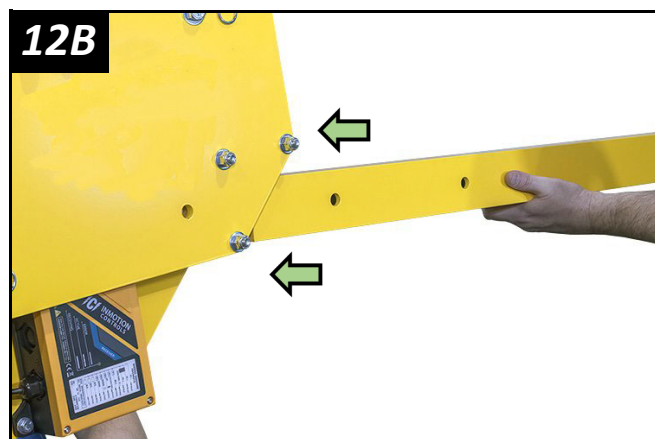
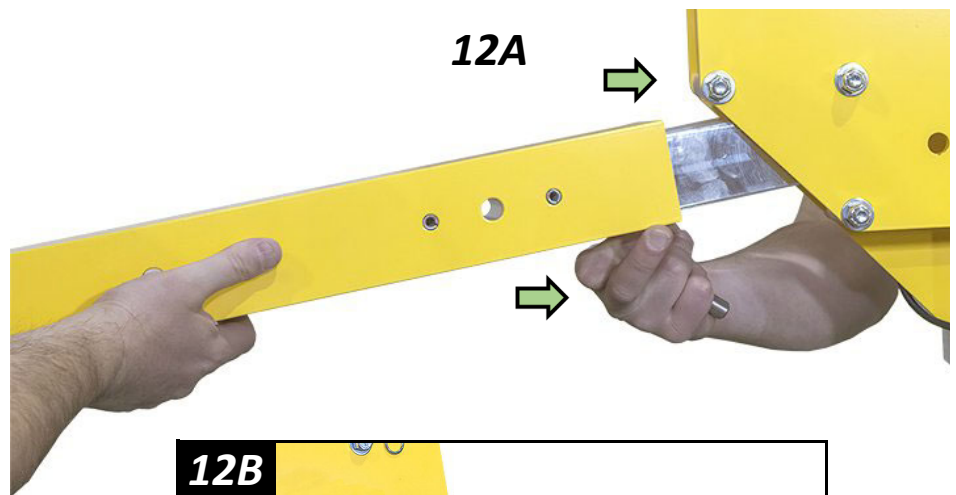

ASSEMBLY



13) Reinstall the sliding pad arms (figs. 13A-B) and secure them with cotterless hitch pins.

14) Reinstall the movable pad mounts and secure them with cotterless hitch pins (fig. 14A).

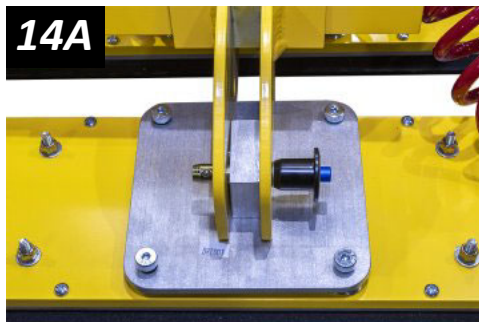

15) Reconnect vacuum hoses (fig. 15A), according to the configuration.

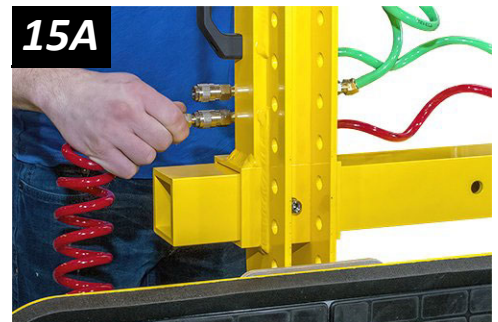

The vertical-to-horizontal reconfiguration is now complete.

ASSEMBLY

Connecting/Disconnecting Vacuum Hoses

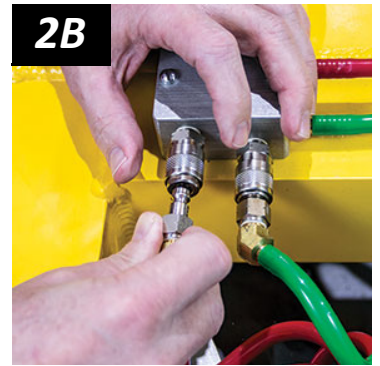
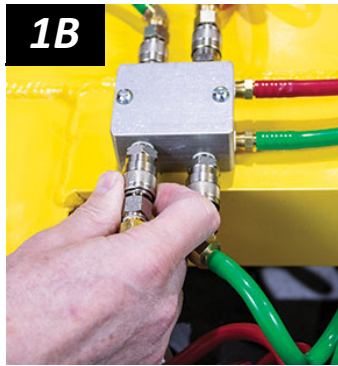
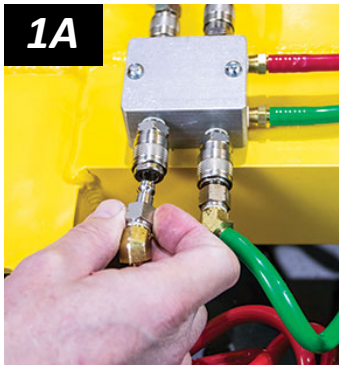

To *connect* a vacuum hose, push the male and female ends of the quick connector together until they lock (figs. 1A-B).



Make sure quick connectors seal completely and all vacuum hoses function correctly (see “Vacuum Test”).

To *disconnect* a vacuum hose, move the release ring on the female end until the quick connector separates (figs. 2A-B).

Make sure all hoses are connected correctly: Green hose to circuit 1 and red hose to circuit 2 (fig. 3A).

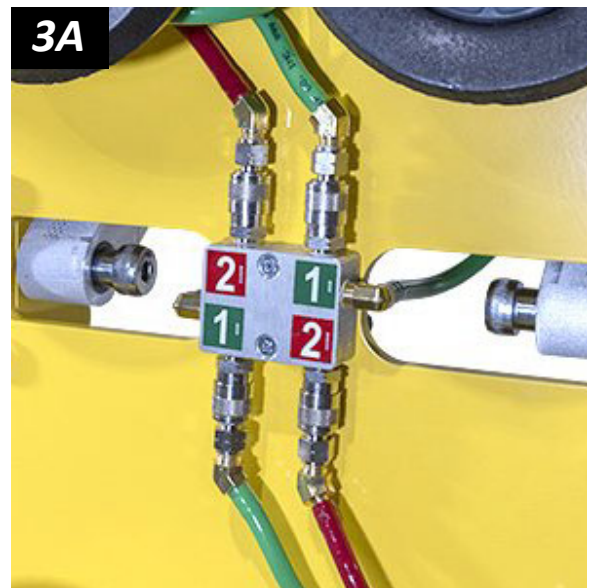

The 2 vacuum gauges are labeled to indicate the related circuits (fig. 4A).

Note: The gauge face colors do not correspond with the circuit colors.



ASSEMBLY

TO INSTALL THE OPTIONAL ROOF PANEL KIT

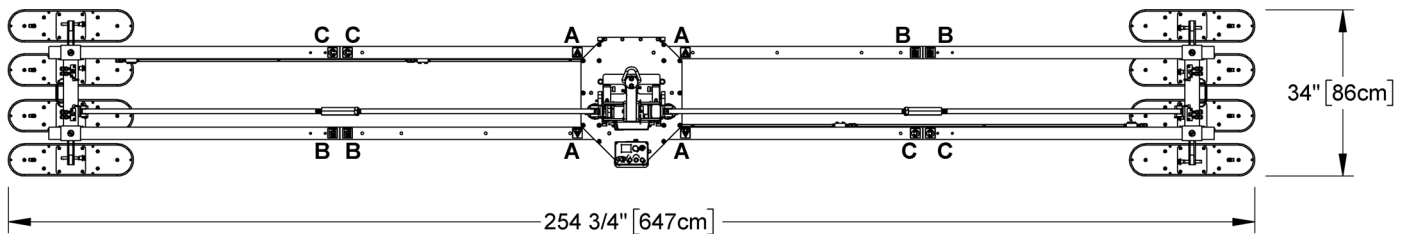
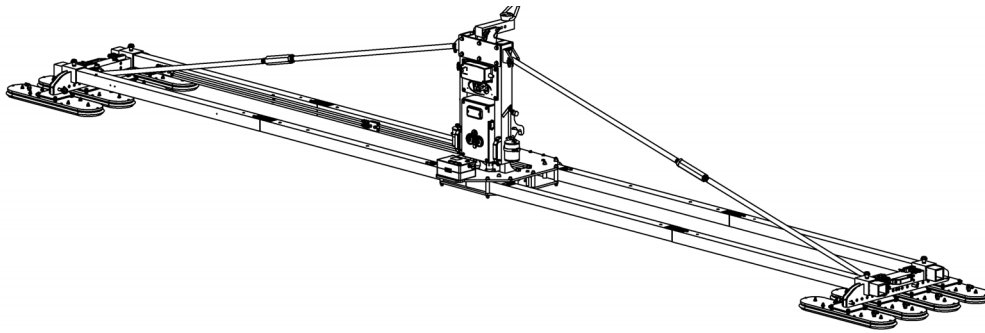

When installed, the Pad Frame Extension Kit (#58397) enables MTEX-DC3 lifters to handle roof panels up to 63' (19.2 m) in length, including “ALLOWABLE OVERHANG”. The illustration above shows the maximum pad spread.

Installation of the kit does not affect Maximum Load Capacity.

In addition to the extension tubes included in the kit, tubes used in the lifter’s standard horizontal orientation are employed when using the kit. All tubes are coded with an “A”, “B” or “C” sticker. Make sure to configure the kit according to the alphabetic code shown in the illustration above.



Remove and/or reposition movable pad mounts as needed to maximize support across a roof panel’s surface [see “[Repositioning \(or Removing\) Movable Pad Mounts](#)”]:

- To support wider panels, move pad mounts outward.
- To support narrower panels, move pad mounts inward.

Note: A minimum of 4 vacuum pads (2 on each side of the pad frame) must be installed and connected when using the kit. The kit can also be configured to a 6-pad configuration, as needed to match a roof panel’s profile. Regardless of the configuration, make sure all pads are parallel to one another and arranged symmetrically.



Make sure all pads are parallel to one another and arranged symmetrically, to avoid accidental load release.



Disconnecting any vacuum pad reduces lifting capacity.

ASSEMBLY

Note: This following steps assumes the MTEX-DC3 is configured in the horizontal orientation, which is required for installation of the Pad Frame Extension Kit. Photos show installation on a model MTEX8625DC3.

- 1) Remove all shipping materials and save them with the shipping container for future use.
- 2) Suspend the lifter from appropriate hoisting equipment that is rated to support the combined Maximum Load Capacity and Lifter Weight with the kit installed.

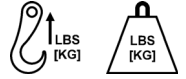

- 3) Make sure the lifter is configured horizontally (see [“TO CHANGE THE PAD FRAME CONFIGURATION”](#)).

- 4) Lock out the tilt latch (see [“Operating the Tilt Latch”](#)).

- 5) Use the hoisting equipment to lower the lifter onto a stable support that will permit reconfiguration of the lifter (eg, folding stand, sawhorses).

! Only use stable support rated for combined weight of lifter and kit (see “SPECIFICATIONS”).

Note: The lifter will move into the flat position as you lower it onto the support.

- 6) Disconnect the vacuum hoses, as previously directed.
- 7) Remove the movable pad mounts from the sliding pad arms, as previously directed.¹ Then remove the pad arms from the pad frame tubes, as previously directed.
- 8) Remove a rubber plug from the lift bar (fig. 8A), to allow installation of a support-rod bracket.



- 9) Install a support-rod bracket on the lift bar, making sure to tighten hardware securely (fig. 9A).

Note: If desired, you can re-install the rubber plug after installing the bracket.



¹..... Because there is no orientation change, removing mounts from the arms is **not** required. However, doing so will make subsequent steps easier.

ASSEMBLY

- 10) Install a support-rod bracket on a sliding pad arm (figs. 10A-B), making sure to tighten hardware securely.



- 11) Install all extension tubes on the pad frame tubes (fig. 11A), making sure to follow the alphabetic codes. Secure the tubes with cotterless hitch pins.

11A

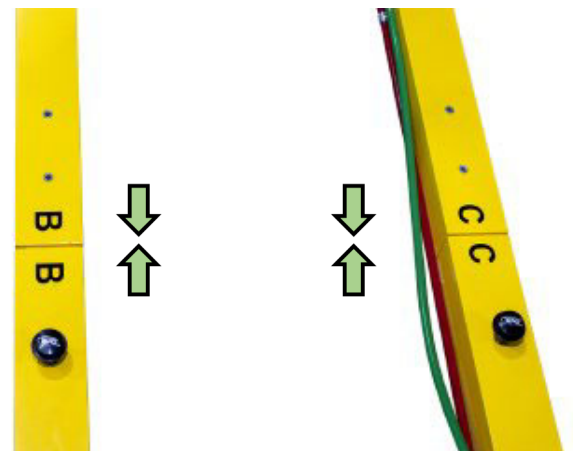

- 12) Align the pin holes of a support rod with the holes on the bracket.

Note: For this step, make sure to select a rod that has a locking nut attached at the opposite end of the rod.

Then insert a mounting pin, as shown in fig. 12A and inset, and secure with a hitch pin.

12A

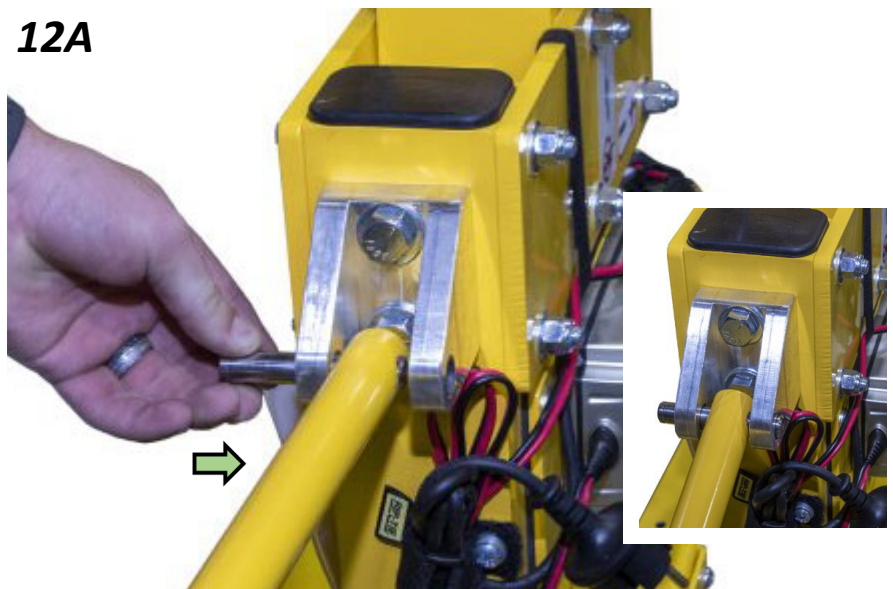

ASSEMBLY

- 13) Thread a support-rod connector on the attached support rod (fig. 13A).

Note: Turn the connector 8 full turns clockwise during this step, to make sure there is at least 1" of threaded connection.



- 14) Thread a support rod on the other end of the support-rod connector (fig. 14A).

Note: Turn the support rod 8 full turns counterclockwise during this step, to make sure there is at least 1" of threaded connection.



- 15) Repeat steps 8 through 14 on the opposite side of the lifter.
- 16) Install a pad arm on the extension tubes, **making sure another person positioned at the opposite end to help keep the lifter balanced on its stable support.** Secure with cotterless hitch pins. **Repeat on the opposite side of the lifter before proceeding.**
- 17) If previously removed, reinstall movable pad mounts on a sliding pad arm, positioning them as needed for the chosen configuration. Secure each mount with a cotterless hitch pin (fig. 17A).

Note: Make sure pad mounts are oriented to allow optimal routing of vacuum hoses (see image of pad mounts under step 19).

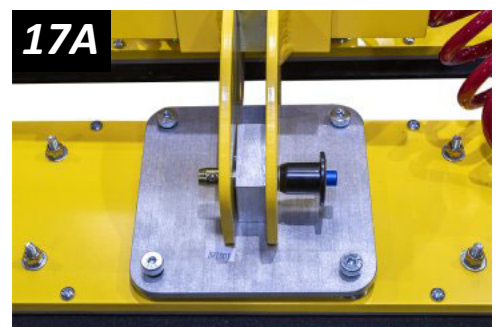

ASSEMBLY

18) Complete a support rod assembly:

18.1) Attach the bottom of the support rod to the sliding pad arm and secure with a mounting pin (fig. 18A) and a hitch pin.



18.2) Using a wrench, turn the support-rod connector (fig. 18B) until the holes of the pad arm and 2 extension tubes align.

Note: Turning the connector clockwise will make the rod assembly shorter, while turning the connector counterclockwise will make the assembly longer.



Then secure the pad arm to the kit's tubes with cotterless hitch pins (circled in fig. 18C).

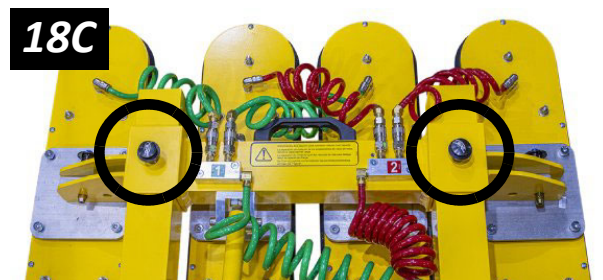

18.3) Continue using the wrench to turn the connector clockwise until the support rod assembly is taut. Then secure the support rod connection with a lock nut (fig. 18D).

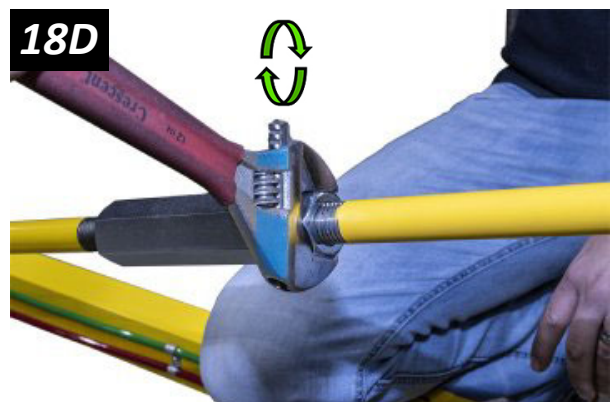

ASSEMBLY

- 19) Reconnect vacuum hoses (fig. 19A and inset), as previously directed.

19A

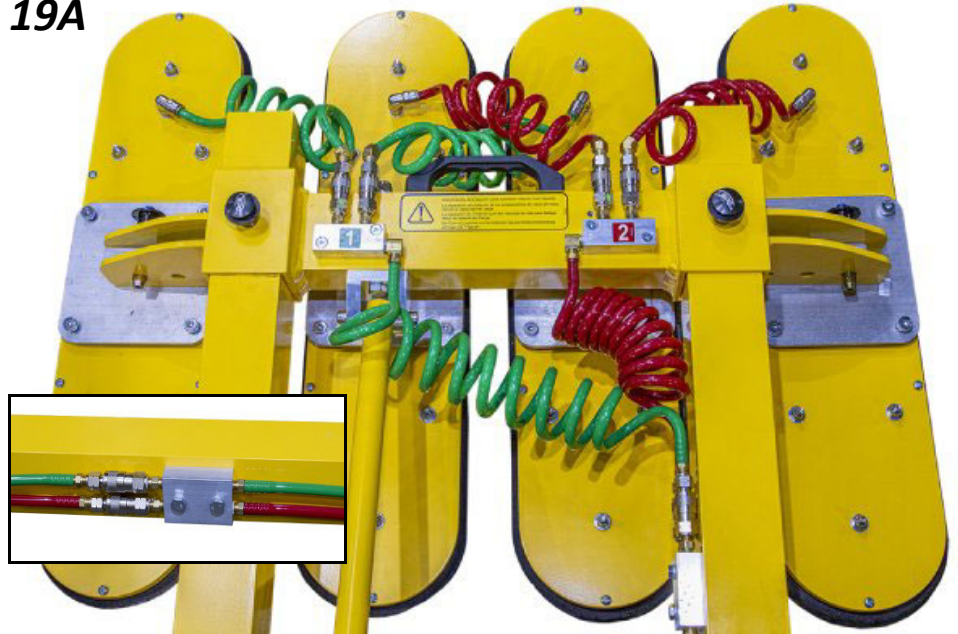

- 20) Repeat steps 16 through 19 on the opposite side of the lifter.

- 21) Position the adjustable lift point mount for use with the kit (see the first page of “ASSEMBLY” for specific adjustment steps). The position shown in fig. 21A provides the optimal hang angle for handling roof panels; other positions should not be used.

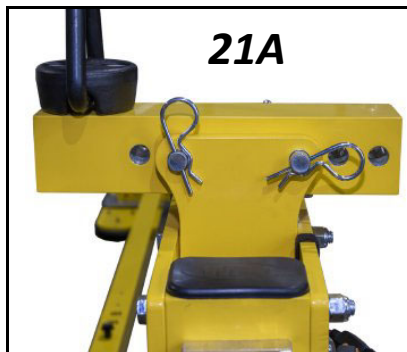

21B



The lifter is now ready to handle roof panels (fig. 21B).

To remove the kit, reverse the preceding steps. However, you do **not** need to remove the support-arm brackets.

INTENDED USE

LOAD CHARACTERISTICS

Make sure the vacuum lifter is intended to handle each load according to these requirements:



Do NOT lift explosives, radioactive substances or other hazardous materials.



- The load weight must not exceed the Maximum Load Capacity.
- The load must be a single piece of relatively nonporous material with a flat and relatively smooth contact surface.¹ Flexible sealing edges on the vacuum pads can accommodate some surface relief, provided contour changes are not too abrupt. To determine whether the load is too porous or rough, perform the “[Lifter/Load Compatibility Test](#)”.
- The load's contact surface must be able to obtain a friction coefficient of 1 with the lifter's vacuum pads (see “[Pad-to-Load Friction Coefficient](#)”). Otherwise, the capacity should be derated appropriately.
- The load's surface temperature must not exceed the Operating Temperatures.²
- The load's *minimum* length and width are determined by the current Pad Spread (see “SPECIFICATIONS”).
- The load's *maximum* length and width are determined by its “[ALLOWABLE OVERHANG](#)”.
- 6" [15 cm] is the allowable thickness at Maximum Load Capacity.³



Note: Standard vacuum pads can stain or deform load surfaces with light colors or soft coatings. Test such surfaces for damaging effects before using the lifter on them.⁴

1..... A “single piece” of material includes curtainwall assemblies, unitized glazing systems and similar construction units.

2..... Vacuum pads made from a heat-resistant rubber compound can enable you to lift loads with higher surface temperatures. Contact WPG or an authorized dealer for more information.

3..... However, the allowable thickness increases as load weight decreases. Contact WPG for more information.

4..... Alternative rubber compounds are available for these purposes. Contact WPG or an authorized dealer for more information.

ALLOWABLE OVERHANG

Insulated Metal Panels Thickness		Maximum Overhang			
		Mineral Core		PIR/ISO/EPS Core	
2.0 in	5.1 cm	8.0 ft	2.4 m	12.5 ft	3.8 m
2.5 in	6.4 cm	9.5 ft	2.9 m	14.5 ft	4.4 m
3.0 in	7.6 cm	10.0 ft	3.0 m	15.5 ft	4.7 m
4.0 in	10.2 cm	12.0 ft	3.7 m	18.0 ft	5.5 m
6.0 in	15.2 cm	14.5 ft	4.4 m	22.0 ft	6.7 m

Chart recommendations based of 24 gauge steel faces

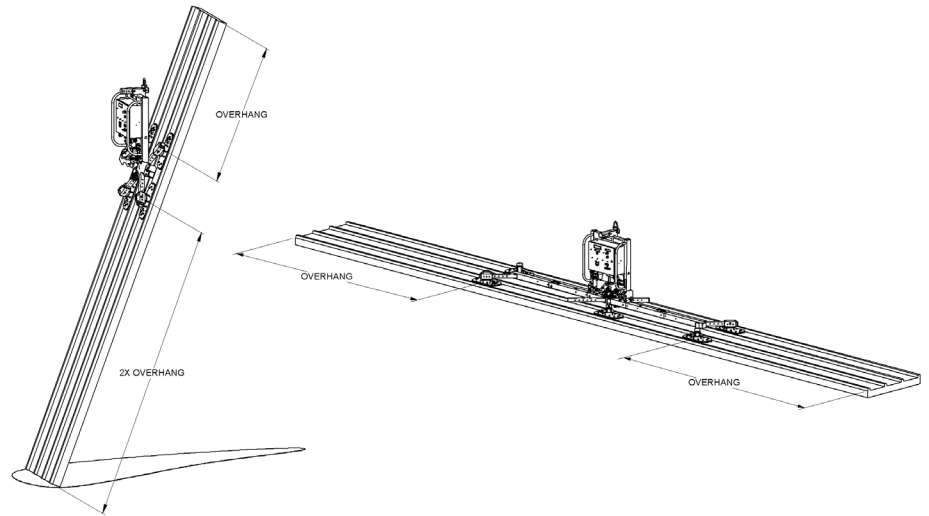

The allowable overhang is the amount of load material that can extend sideways beyond the vacuum pads without breaking or otherwise being damaged. This depends on the load material, its thickness, and the angle of handling. Since every material has different physical properties, the allowable overhang must be evaluated separately for each load type. For insulated metal panels, consult the chart above for allowable overhang recommendations.¹

INDIRECT LOADING

Make sure to account for dynamic loading or other inadvertent loading that can negatively affect lifting capacity, such as:

- Weight amplification that results when a loaded vacuum lifter abruptly starts/stops moving, changes direction or bounces up and down (eg, when a telehandler transports a loaded lifter across rough terrain).
- External force that effectively increases the weight of a lifter's attached load (eg, when a load of sheet material reacts to wind gusts).

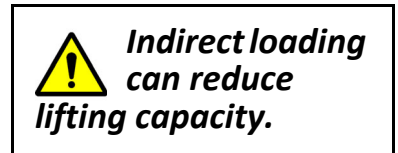

¹..... Contact the panel manufacturer for more detailed information, if needed.

INTENDED USE

OPERATING ENVIRONMENT

Make sure the lifter is suitable for each work environment, given the following restrictions:

- This lifter is not intended for any environment that is dangerous to the operator or damaging to the lifter. Avoid environments containing explosives, caustic chemicals and other dangerous substances.



Never use lifter in dangerous environments.



Metal particles and similar environmental contaminants could result in vacuum pump failure.

- The work environment is limited by the Operating Elevation and Operating Temperatures.^{1, 2}

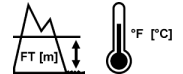

- The lifter is not designed to be watertight. Do not use it in rain or other unsuitable conditions.



Moisture can reduce lifting capacity.

DISPOSAL OF THE LIFTER

After the Service Life of the lifter has ended (see “SPECIFICATIONS”), dispose of it in compliance with all local codes and applicable regulatory standards.

Note: Special disposal regulations may apply to the battery.

1..... Although lifter use may be possible at higher elevations, lifting capacity is reduced whenever the lifter is unable to attain vacuum in the green range on the vacuum gauges. Contact WPG for more information.

2..... Special provisions may allow the lifter to operate outside the specified temperature range. Contact WPG for more information.

OPERATION

BEFORE USING THE LIFTER

Determine whether the vacuum lifter is capable of each intended task (see “SPECIFICATIONS” and “[INTENDED USE](#)”). Then complete the following preparations:

Taking Safety Precautions

- Be trained in all industry and regulatory standards for lifter operation in your region.
- Follow trade association guidelines about precautions needed for each load material.



Read all directions and safety rules before using lifter.



Always wear appropriate personal protective equipment.

Selecting a Screen Language

When the lifter is powered up for the first time, the [Intelli-Grip® control unit](#) prompts the operator to select a language for the [LCD screen](#). Use the buttons as follows:



- To scroll down, press the “[release](#)” button (|→|).
- To scroll up, press the “[attach](#)” button (|←|).
- To select a language, press the “[function](#)” button (Fn).¹



Note: A similar process is used to navigate all menus.

¹..... To change the language again, refer to the “INTELLI-GRIP® OPERATOR MENUS” section of the [SERVICE MANUAL](#).

OPERATION

Performing Inspections and Tests

- Follow the “[INSPECTION SCHEDULE](#)” and “[TESTING](#)”.
- Service the 2 [air filters](#) whenever a bowl contains liquid or other contaminants, or an element appears dirty (see “[AIR FILTER MAINTENANCE](#)” in [SERVICE MANUAL](#)).
- Make sure the [notification buzzer](#) is clearly audible at the maximum distance between the operator and the lifter, despite any barriers or obstacles.^{1, 2}



Examine air filters regularly and service when needed.



Make sure notification buzzer can be heard over noise at operator position.

Checking the 12-Volt Battery



Always check [battery energy](#) before every lift.

While the lifter is powered up, a [battery gauge](#) on the [LCD screen](#) displays the current energy level.^{3, 4}

- If battery energy is in the red range, discontinue lifter use and charge the battery (see “[12-VOLT BATTERY RECHARGE](#)”).
- If battery energy continues to decrease and you try to attach the lifter to a load, the [notification buzzer](#) will sound continuously and the LCD screen will display “Lockout (low 12V battery)”, along with a diagnostic code (see “[INTELLI-GRIP® DIAGNOSTIC CODES](#)”). In this case, you must charge the battery in order to continue using the lifter.

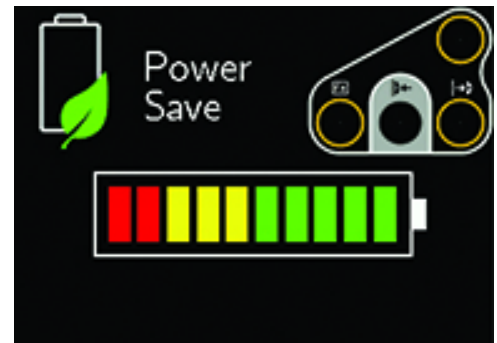

1..... Maximum buzzer volume is 95 dBA at 2' [60 cm]. If CE or UKCA Standards apply, consult EN 7731 to make sure the notification buzzer is compliant.

2..... The “[Vacuum Test](#)” provides a convenient opportunity to check this.

3..... If the lifter remains in “Power Save” mode for a long time, the pump will run periodically to test the battery.

4..... If the battery charger is connected to an AC power source, the reading on the battery gauge will not be accurate and “Replace 12V battery?” may appear on the LCD screen, because the system cannot accurately evaluate the battery.

OPERATION

Preparing to Use the Remote Control System

 The optional radio transmitter (fig. 1A) and radio receiver enable you to activate the lifter's "attach" and "release" functions at distances up to 250' [76 m], provided you have a clear and direct view of the lifter and its status indicators.

To operate a lifter remotely, follow these safety rules:

- Visually verify the status of the lifter and load prior to lifting.



Make sure nearby personnel are aware of intended remote control actions.

- Monitor the lifter at all times to make sure it is functioning as intended.¹
- Be sure the load is lowered and supported correctly before releasing it (see following sections).

Note: To prevent any radio transmission, press the emergency disconnect button.²

1A



- 1 EMERGENCY DISCONNECT BUTTON
- 2 TRANSMISSION INDICATOR LIGHT
- 3 "RELEASE" BUTTON
- 4 "ATTACH" BUTTON
- 5 POWER/"FUNCTION" BUTTON

1..... The Remote Control System is designed to prevent multiple lifters from responding. Nevertheless, radio-controlled lifters should be tested to make sure each transmitter controls only one lifter.

2..... To reset the emergency disconnect button, twist the button clockwise and allow it to spring outward to its original position.

OPERATION

To ATTACH THE PADS TO A LOAD

Make sure that the contact surfaces of the load and vacuum pads are clean (see “[Pad Cleaning](#)”).



Positioning the Lifter on the Load

1) Position the lifter as needed to support the load correctly:

- To install vertically oriented wall panels, the lifter is normally positioned “*above center*” (fig. 1A).

Center the pad frame from left to right on the load, and position the vacuum pads towards what will be the top end while lifting.

 **When lifter is “above center”, make sure tilt latch is unlocked.**

Make sure the tilt latch is not locked out (fig. 1B), to avoid unexpected load release and lifter damage (see “[Operating the Tilt Latch](#)”).

1B



NOT LOCKED OUT

LOCKED OUT



OPERATION

- To install roof panels and horizontally oriented wall panels, the lifter must be positioned “on center” (fig. 1C).

Center the pad frame to within 2" [5 cm] of the load center, to avoid unexpected tilt and lifter damage.¹

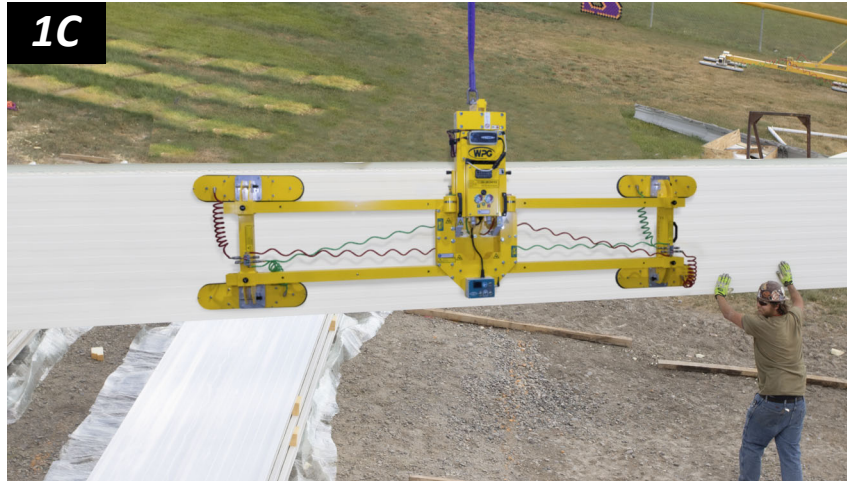

- 2) Make sure that all vacuum pads will fit on the load and will be loaded evenly. Consult the Per-Pad Load Capacity.
- 3) Place the vacuum pads in contact with the load surface.



Avoid interference between lift point and load.

Note: Position the adjustable lift point mount (item 1 in fig. 1D) as needed to avoid interference with the load (item 2 in fig. 1D) when lifted or tilted (see “ASSEMBLY”). Failure to do so could damage the lifter and load (circled in fig. 1D), or result in an unexpected load release.

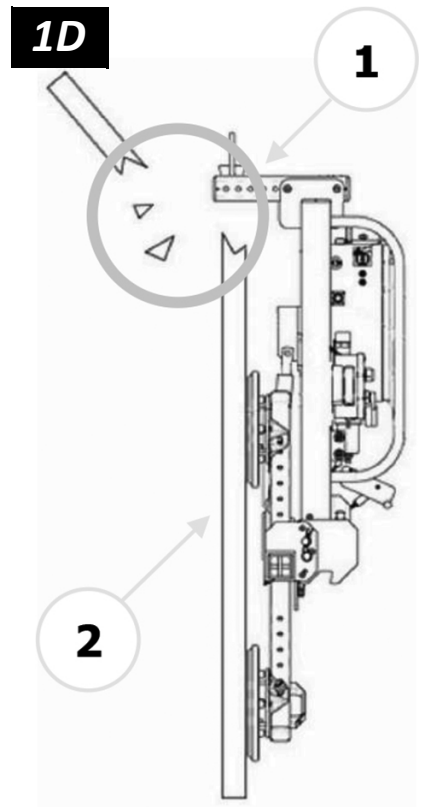

1..... The lifter is designed to handle the maximum load weight when the load’s center of gravity is positioned within 2" [5 cm] of the pad frame’s center point. Uncentered loads may tilt unexpectedly.

OPERATION

Powering up the Lifter

Press the lifter's power button (⏻ — fig. 1A). The vacuum pump will run for a few seconds, as a normal function of the Intelli-Grip® self-diagnostics.

The lifter automatically tests the 9-volt battery for the notification buzzer each time the lifter is powered up. When this battery runs down, the LCD screen displays “Replace 9V battery?” and the buzzer chirps once per minute. Replace the battery as needed (see “[NOTIFICATION BUZZER BATTERY REPLACEMENT](#)”).

 To use the optional Remote Control System, briefly hold the power button (⏻ — fig. 1B) on the radio transmitter to activate it.¹

Note: When you hold any button on the transmitter, the transmission indicator light flashes green if the transmitter is activated.



Sealing the Pads on the Load

Press the lifter's “attach” button (⏻ — fig. 1C).

 **Keep “attach” function activated throughout lift.**



 To use the optional Remote Control System, press the “attach” button (⏻ — fig. 1D) on the radio transmitter.



1..... The radio transmitter turns off automatically after a period of inactivity.

OPERATION

The vacuum pump will run until the vacuum pads seal completely. If the lifter takes too long to attach, the notification buzzer chirps and the LCD screen displays “Vacuum not increasing normally”, along with a diagnostic code (see “[INTELLI-GRIP® DIAGNOSTIC CODES](#)”). In this case, press the lifter firmly against the load to help the pads begin to seal.¹

Reading the Vacuum Gauges

The 2 vacuum gauges of the dual vacuum system show the current vacuum level in positive inches of Hg and negative kPa:

- *Green range* (≥ 16 " Hg [≤ -54 kPa]): Vacuum level is sufficient to lift the maximum load weight (fig. 1A).
- *Red range* (< 16 " Hg [> -54 kPa]): Vacuum level is **not** sufficient to lift the maximum load weight (fig. 1B).²

If it takes more than 5 seconds for the vacuum level to reach 5" Hg [-17 kPa] on either vacuum gauge, press on any vacuum pad that has not yet sealed.

Once the pads have sealed, the lifter should be able to maintain sufficient vacuum for lifting, except when used above the maximum Operating Elevation.³ If it does not, perform the “[Vacuum Test](#)”.

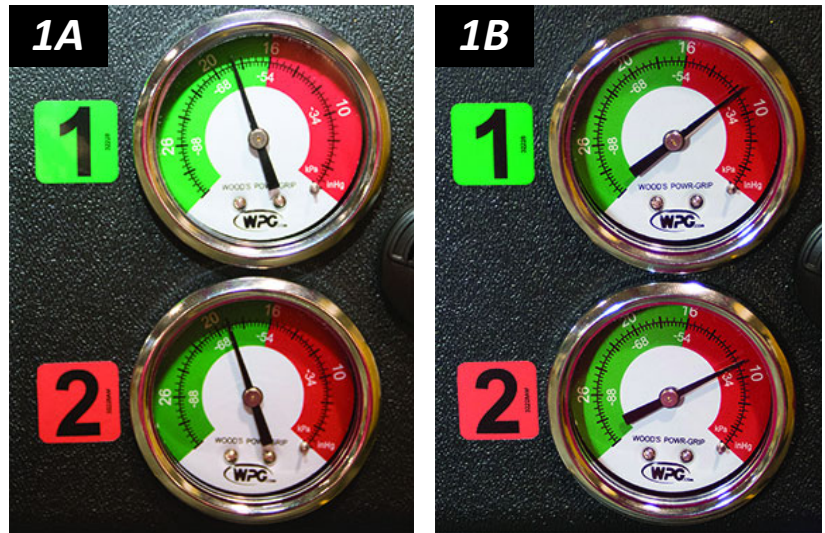

1..... Although a vacuum pad may become distorted during shipping or storage, this condition should correct itself with continued use.

2..... The gauge face colors do not correspond with the circuit colors.

3..... If the lifter is used above the maximum Operating Elevation (see “[SPECIFICATIONS](#)”), it may not be able to maintain sufficient vacuum for lifting. Contact WPG for more information.

OPERATION

To Lift and Move the Load



Lift bar must be vertical to lift load.

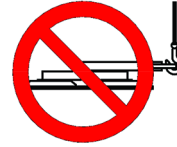
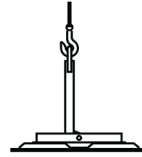

Interpreting the Lift Light



When vacuum is sufficient to lift the Maximum Load Capacity, the vacuum lift light turns *on* automatically and the vacuum pump turns *off* temporarily, to conserve battery energy.



Never lift load unless lift light is illuminated, because premature lifting could result in load release and personal injury.

Monitoring Vacuum Indicators

Monitor the vacuum lift light and both vacuum gauges throughout the entire lift (fig. 1A).



Make sure all vacuum indicators remain completely visible.

The vacuum pump turns on and off to overcome any leakage. However, if the leak rate is greater than normal, the notification buzzer chirps and the LCD screen displays the message “Vacuum decrease on circuit #”, along with a diagnostic code (see “[INTELLI-GRIP® DIAGNOSTIC CODES](#)”).¹ Such leaks can cause the battery to be discharged more quickly.

If the vacuum pump is unable to overcome leakage, the notification buzzer sounds continuously, the lift light turns off, and the LCD screen displays the message “INSUFFICIENT VACUUM!”, along with a diagnostic code (see “[INTELLI-GRIP® DIAGNOSTIC CODES](#)”). If this happens:

- 1) Keep everyone away from a suspended load until it can be safely lowered to a stable support.



Stay clear of any suspended load while indicators warn of insufficient vacuum.



1.... Automatic leak detection is **not** a substitute for performing the “[Vacuum Test](#)”, required by the “[INSPECTION SCHEDULE](#)” and “[TESTING](#)”. Sensitivity of leak detection can be adjusted (see “[INTELLI-GRIP® OPERATOR MENUS](#)” in [SERVICE MANUAL](#)).

OPERATION

- 2) Stop using the lifter until the cause of the vacuum loss can be identified: Conduct the “[Pad Inspection](#)” and perform the “[Vacuum Test](#)”.
- 3) Correct any faults before resuming normal operation of the lifter.

Controlling the Lifter and Load

When the lifter is ready, use the hoisting equipment to raise the lifter and load as needed.

Use a control handle (fig. 1A) or other appropriate means, such as control lines, to keep the lifter and load in the required position.

Once there is enough clearance, you may move the load as required.

If the lifter is positioned “*above center*” on a load in the flat orientation, make sure the tilt latch is not locked out (see “[Operating the Tilt Latch](#)”). Otherwise, an unexpected load release or damage to the lifter could result.

If the load is positioned “*on center*”, the load can be tilted as required once there is enough clearance (see “[TO TILT THE LOAD](#)”).

In Case of a Power Failure

In the event of a battery failure or electrical system failure, the notification buzzer will sound continuously.

Although the vacuum reserve tanks are designed to support the load for at least 5 minutes without power, this depends on many factors, including the “[LOAD CHARACTERISTICS](#)” and the condition of vacuum pads (see “[VACUUM PAD MAINTENANCE](#)”).

If a power failure occurs, keep everyone away from a suspended load until it can be lowered safely to a stable support. Correct any faults before resuming normal operation of the lifter.



Stay clear of any suspended load during power failure.

To TILT THE LOAD



Make sure load is positioned correctly on lifter (as previously directed).

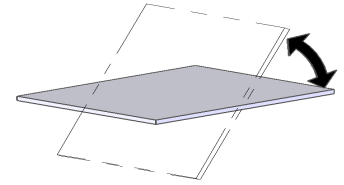

- 1) Make sure the load has enough clearance to tilt without contacting anyone or anything.
- 2) Use the control handles, control lines or other appropriate means to keep the load under control at all times.
- 3) Follow the appropriate procedure:

Tilting Loads When Lifter is Positioned “Above Center”

Make sure the tilt latch is not locked out (see “[Operating the Tilt Latch](#)”), to avoid an unexpected load release and damage to the lifter or load.



When lifter is “above center”, make sure tilt latch is not locked out.

The load will automatically tilt from the flat position to the upright position when the loaded lifter is lifted by hoisting equipment (fig. 1A).

To tilt the load from the upright position to the flat position, use the hoisting equipment to lower the load until its lower edge is adequately supported. Then move the lifter forward and downward until the load reaches the flat position.



OPERATION

Tilting Loads When Lifter is Positioned “On Center”

Disengage the tilt latch (see “[Operating the Tilt Latch](#)”) and prepare for a slight surge of motion as the load begins to tilt. Pull upward or press downward on the nearest pad frame tube to tilt the load as required. Continue to apply pressure as needed to maintain the desired tilt angle.

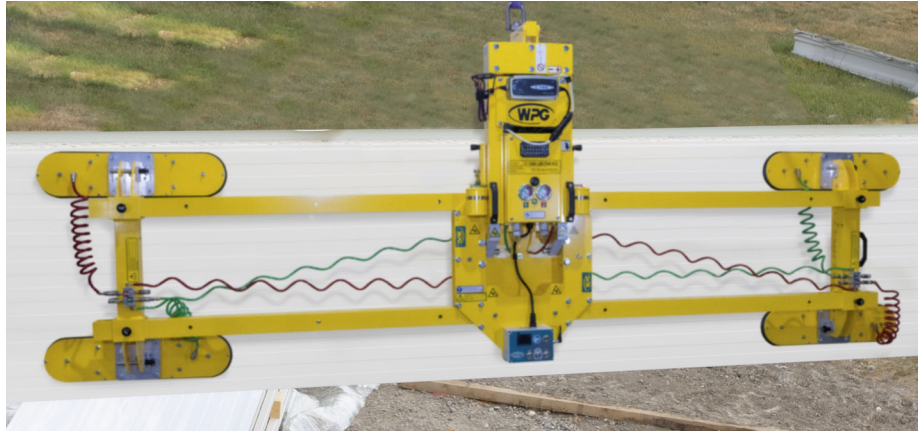

A load with overhang may force you to let go of the tube as the load approaches the flat position. In this case, use hand cups, control lines or other appropriate means to control the load.

Operating the Tilt Latch

The pad frame automatically latches in place when the load reaches the upright position (fig. 1A-B), unless the tilt latch is locked out.

Whenever tilt is not required, keep the tilt latch engaged, to prevent load damage or personal injury.

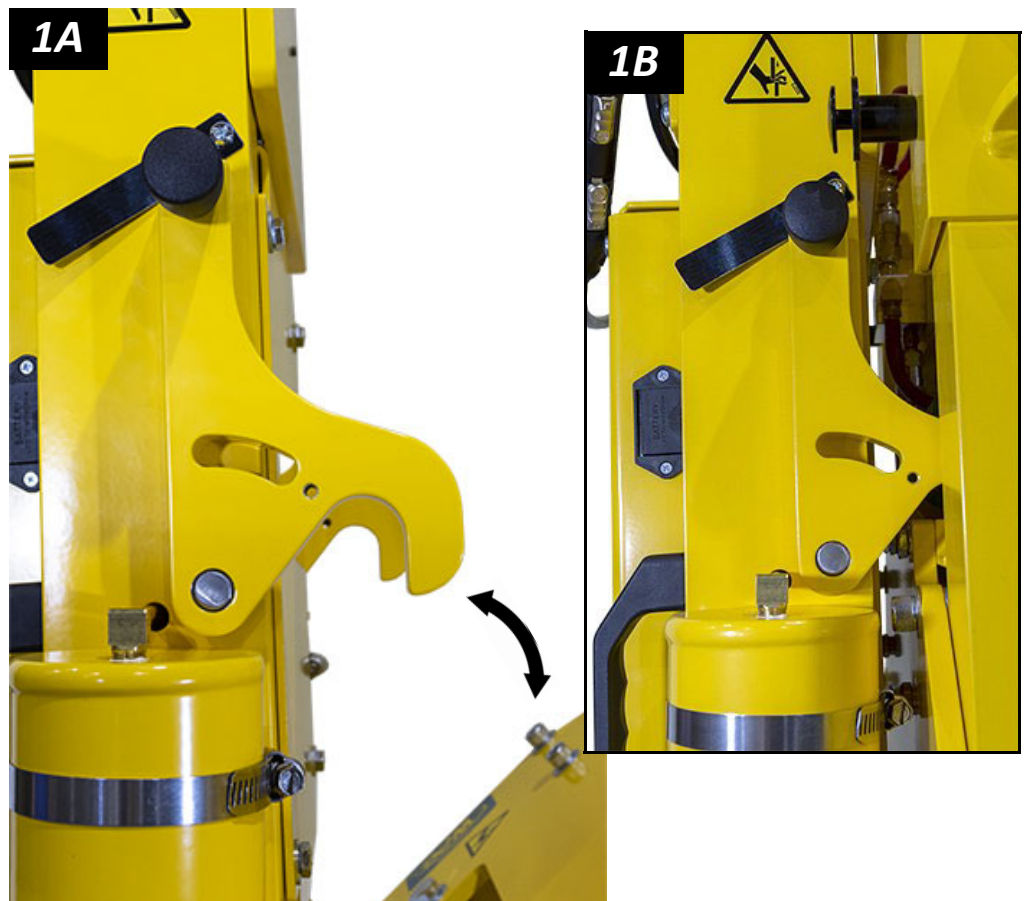

OPERATION

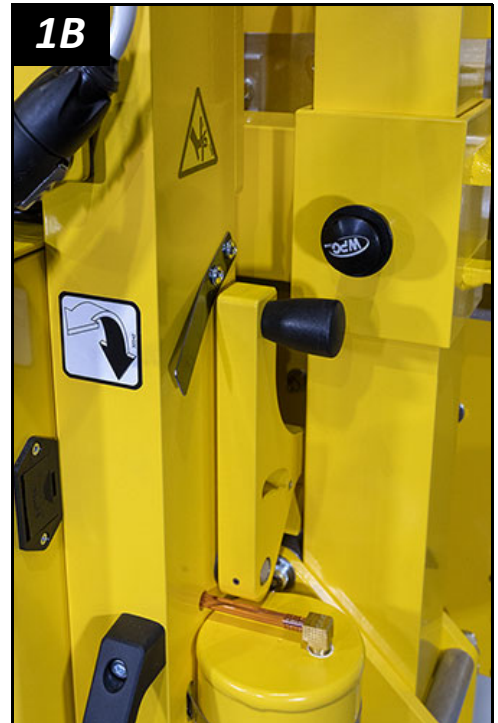

The lifter has 2 control levers (circled in fig. 1A) for disengaging the tilt latch. However, the lifter has only 1 lock-out mechanism that keeps the latch disengaged. It is located on the right-hand side of the lift bar (fig. 1B).

If you want the tilt latch to function automatically, pull a control lever *part of the way* toward you (fig. 1C), begin to tilt the load, and release the control lever.¹

If you want to **lock out** the tilt latch, so that it will *not* engage at any time during the tilt, pull the control lever *all the way* toward you until the lock-out mechanism secures the lever in place (fig. 1D).



1..... Automatic latching can be defeated by continuing to hold the control lever so that the tilt latches do not engage.

OPERATION

TO RELEASE THE PADS FROM THE LOAD



Make sure load is at rest and fully supported before releasing vacuum pads.

- 1) Hold the “function” button (Fn) — fig. 1A) and the “release” button (↵) — fig. 1A). If the vacuum seal does not break, follow the directions on the LCD screen.



To use the optional Remote Control System, hold the “function” button (⏏) — fig. 1B) and the “release” button (↵) — fig. 1B) on the radio transmitter.



Note: The strobe light (fig. 1C) flashes while the “function” or “release” button is held, to show the operator that signals are being transmitted and to warn others that the operator may be releasing the load.

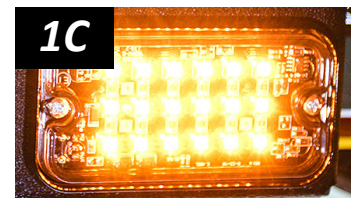

- 2) Continue to hold the “function” and “release” buttons until the vacuum pads release the load completely. Otherwise, the vacuum lifter will automatically revert to “attach” mode.¹



Do not move lifter until pads release completely, because such movement could result in load damage or personal injury.



After the load is successfully released, the lifter activates the “Power Save” mode automatically.

- 3) Before you lift another load, perform the Every-Lift Inspection (see “[INSPECTION SCHEDULE](#)”).

1..... A “Timed Release” function can be used to help separate the lifter from the load: Hold the “function” and “release” buttons until a yellow arrow appears on the LCD screen. Then tap the “function” button 2 or more times. This prolongs the release mode for 5 seconds per each additional tap.

OPERATION

AFTER USING THE LIFTER

- 1) Press the power button (, fig. 1A) and the “function” button (, fig. 1A) to power down the vacuum lifter.
- 2) Charge the battery after each workday as needed (see [“12-VOLT BATTERY RECHARGE”](#)).¹
- 3) Use the hoisting equipment to lower the lifter gently onto a stable support.



Caution: Do not set lifter on surfaces that could soil or damage vacuum pads. Make sure all pads rest on spacers, to protect their sealing edge.²

- 4) Continue using the hoisting equipment to lower the lift bar. Then place a support under the adjustable lift point mount.
- 5) Detach the hoisting hook from the lift point.

Storing the Lifter

- 1) Use the covers supplied to keep the vacuum pads clean (fig. 1B).

CE/UKCA – To prevent the lifter from tipping over on relatively horizontal surfaces, place the vacuum pads facedown on a clean, smooth, flat surface. Then lower the lift bar and place a support under the adjustable lift point mount.



- 2) Charge the battery completely and repeat every 6 months (see [“12-VOLT BATTERY RECHARGE”](#)).

1..... To maximize battery life, charge it promptly after each use.

2..... Spacers are integrated into the original shipping container. Use similarly shaped spacers when setting the lifter on other surfaces.

OPERATION

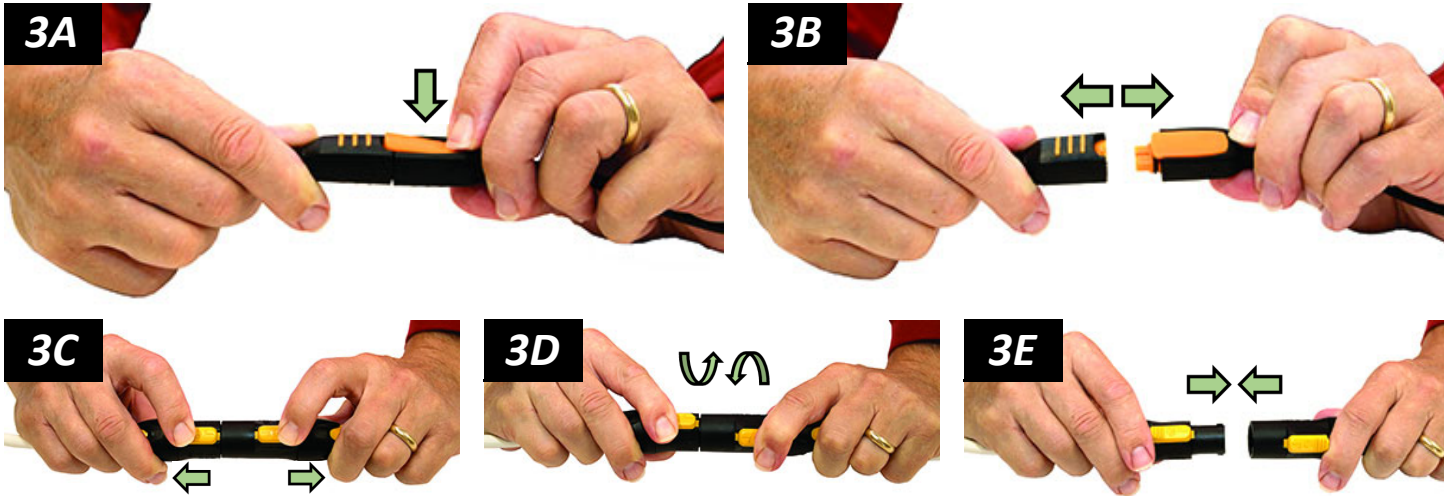

3) Disconnect the electrical connectors (figs. 3A-B and 3C-E), to prevent battery discharge.

4) Store the lifter in a clean, dry location.

Store the battery between 32° and 70° F [0°– 21° C]. Avoid storage above 100° F [38° C].

Transporting the Lifter

Secure the lifter in the original shipping container with the original shipping materials or equivalent.

INSPECTIONS AND TESTS

INSPECTION SCHEDULE

Perform inspections according to the following frequency schedule. If any fault is found, correct it and perform the next most frequent inspection before using the vacuum lifter.

Note: If a lifter is used less than 1 day in a 2-week period, perform the Periodic Inspection before using it.

Action	Every Lift	Frequent ¹ (Every 20-40 hrs.)	Periodic ² (Every 250-400 hrs.)
Examine <u>vacuum pads</u> for contaminants or damage (see “ Pad Inspection ”).	✓	✓	✓
Examine load surface for contaminants or debris.	✓	✓	✓
Examine controls and indicators for damage.	✓	✓	✓
Examine lifter’s structure for damage.		✓	✓
Examine vacuum system for damage (including <u>vacuum pads</u> , fittings and hoses).		✓	✓
Examine <u>air filters</u> for conditions requiring service (see “AIR FILTER MAINTENANCE” in SERVICE MANUAL).		✓	✓
Perform “ Vacuum Test ”.		✓	✓
Check for unusual vibrations or noises while operating lifter.		✓	✓
 If the lifter has a Remote Control System, perform “ Remote Control System Test ”.		✓	✓
Examine entire lifter for evidence of: <ul style="list-style-type: none"> • looseness, excessive wear or excessive corrosion • deformation, cracks, dents to structural or functional components • cuts in vacuum pads or hoses • any other hazardous conditions 			✓
Inspect entire electrical system for damage, wear or contamination that could be hazardous, in compliance with all local codes and regulatory standards. Caution: Use appropriate cleaning methods for each electrical part, as specified by codes and standards. Improper cleaning can damage parts.			✓

1..... The Frequent Inspection is also required whenever the lifter has been out of service for 1 month or more.

2..... The Periodic Inspection is also required whenever the lifter has been out of service for 1 year or more. Keep a written record of all Periodic Inspections. If necessary, return the lifter to WPG or an authorized dealer for repair (see “[REGISTRATION AND LIMITED WARRANTY](#)”).

TESTING

Perform the following test to determine whether or not a load surface is too porous or rough:

Lifter/Load Compatibility Test¹

- 1) Make sure the vacuum generating system is functioning correctly (see “[Vacuum Test](#)”).
- 2) Thoroughly clean the load surface and the vacuum pads (see “[Pad Cleaning](#)”).²
- 3) Place the load in the upright/flat position on a stable support.
- 4) Attach the vacuum pads to the load as previously directed.
- 5) After the vacuum pump stops running, hold the “function” button (**(Fn)**) and the “power” button (**(⏻)**) for at least 5 seconds to power down the vacuum lifter.

Note: During this time the LCD screen displays “WARNING! Is load attached?”, the notification buzzer chirps rapidly and the strobe light flashes.

- 6) Raise the load a minimal distance, to make sure it is supported by the lifter.
- 7) Watch each vacuum gauge: **Starting from a vacuum level of 16" Hg [-54 kPa], the lifter must maintain a vacuum level greater than 12" Hg [less than -41 kPa] for 5 minutes.**³ If not, lifting this load requires additional precautions (eg, a load sling). Contact WPG for more information.
- 8) Lower the load *after* 5 minutes or *before* the vacuum level diminishes to 12" Hg [increases to -41 kPa].



Take precautions in case load should fall during test.

1..... The “[Pad-to-Load Friction Coefficient](#)” can affect the outcome of this test.

2..... Contaminated loads can also cause the vacuum pump to run frequently or continuously. Since excessive pumping quickly reduces battery energy, clean the load whenever possible.

3..... Under CE and UKCA requirements, the lifter must maintain a vacuum level **greater than 8" Hg [less than -27 kPa]**.

INSPECTIONS AND TESTS

Perform the following tests before placing the lifter in service *initially* and *following any repair*, when directed in the “*INSPECTION SCHEDULE*”, or *whenever necessary*:

Operational Tests

Test all features and functions of the lifter (see “OPERATING FEATURES” and “OPERATION”).

Vacuum Test

- 1) Clean the face of each vacuum pad (see “*Pad Cleaning*”).
- 2) Use a test load with weight equal to the Maximum Load Capacity, a clean, smooth, nonporous surface and other appropriate “*LOAD CHARACTERISTICS*”.¹ 
- 3) Attach the lifter to the test load as previously directed. After the vacuum pump stops running, the vacuum level should appear in the green range on each of the vacuum gauges.
- 4) Raise the load a minimal distance. Then hold the “function” button (Fn) and the “power” button (⏻) for at least 5 seconds to power down the lifter.²

 **Take precautions in case load should fall during test.**
- 5) Watch the vacuum gauges: *The vacuum level should not decrease by more than 4" Hg [increase by more than 14 kPa] in 5 minutes.*
- 6) Lower the load after 5 minutes or whenever a lifter fails the test, and release the load as previously directed.

 **Never use lifter that has failed test.**
- 7) Qualified service personnel must correct any fault in the vacuum system before the lifter can be returned to service.

 **This service must be performed by qualified service personnel.**

1..... The load should have either a flat surface or no more curvature than the lifter is designed for, if any.

2..... During this time, the LCD screen displays “WARNING: Is load attached?”, the notification buzzer chirps and the strobe light flashes.

INSPECTIONS AND TESTS

Rated Load Test¹

The following steps must be performed or supervised by a qualified person:²

- 1) Use a test load that weighs 125% ($\pm 5\%$) of the Maximum Load Capacity and has the appropriate “LOAD CHARACTERISTICS”. 
- 2) Attach the vacuum pads to the load as previously directed.
- 3) Position the load to produce the greatest stress on the lifter consistent with “INTENDED USE”.
- 4) Raise the load a minimal distance and leave it suspended for 2 minutes.
- 5) Once the test is completed, lower and release the load as previously directed.
- 6) Inspect the lifter for any stress damage, and repair or replace components as necessary to successfully pass the test.
- 7) Prepare a written report of the test and keep it on file.



Take precautions in case load should fall during test.



Never use lifter that has failed test.

Remote Control System Test

 If the lifter has a Remote Control System, test it where the lifter is normally used. Use the radio transmitter to activate each of the remote functions.³ Vary the transmitter's direction and distance from the lifter, to make sure transmissions are effective.⁴

If the Remote Control System is not functioning correctly, ...

- the battery for the radio transmitter may need to be replaced, or;
- metal or other electrically conductive surfaces may be causing radio interference. Reposition the transmitter to transmit signals effectively.

If the problem persists, vary the test conditions, to determine whether there is transmission interference in the work environment or the Remote Control System is not functioning. Correct any fault before using the Remote Control System.

1..... An equivalent simulation may also be used. Contact WPG for more information.

2..... A “qualified person” has successfully demonstrated the ability to solve problems relating to the subject matter and work, either by possessing a recognized degree in an applicable field or a certificate of professional standing, or by possessing extensive knowledge, training and experience.

3..... Use a test material with appropriate “LOAD CHARACTERISTICS” to test the “attach” and “release” functions.

4..... This may require assistance from someone near the lifter, to verify functions are working as intended.

MAINTENANCE

Note: Refer to **SERVICE MANUAL #36106** when applicable.

VACUUM PAD MAINTENANCE

Pad-to-Load Friction Coefficient

The friction coefficient represents the lifter's ability to resist load slippage. The Maximum Load Capacity assumes a friction coefficient of 1, based on testing of clean, new, standard rubber vacuum pads on clean, dry, regular glass. **If the lifter is used under other conditions, a qualified person must first determine the effective lifting capacity.**¹

Long-term exposure to heat, chemicals or UV light can reduce the friction coefficient of vacuum pads. Replace pads and sealing rings or replaceable inserts every 2 years or more often when necessary.

Pad Inspection

Inspect each vacuum pad (fig. 1A) according to the "INSPECTION SCHEDULE" and correct the following faults before using the lifter (see "REPLACEMENT PARTS", when applicable):

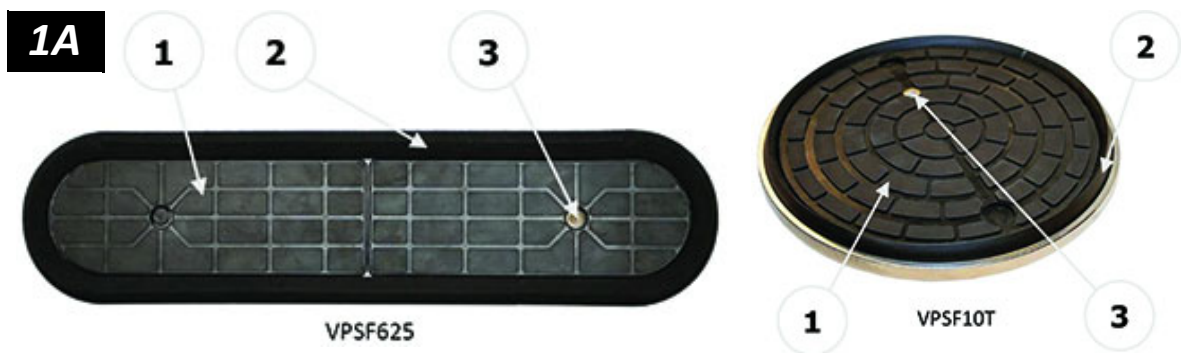

- Contaminants on the face (item 1 in fig. 1A) or sealing edges (item 2 in fig. 1A).
- Filter screen (item 3 in fig. 1A) missing from face.
- Nicks, cuts, deformation or abrasions in sealing edges.



Replace any sealing ring or pad insert that has damaged sealing edges (see "TO REPLACE SEALING RING IN VPFS10T PADS" or "TO REPLACE PAD INSERTS IN VPFS625 PADS", where applicable).

1..... A "qualified person" has successfully demonstrated the ability to solve problems relating to the subject matter and work, either by possessing a recognized degree in an applicable field or a certificate of professional standing, or by possessing extensive knowledge, training and experience.

MAINTENANCE

Pad Cleaning



- 1) Regularly clean the face of each vacuum pad (fig. 1A), using soapy water or other mild cleansers to remove oil, dust and other contaminants.

Solvents, petroleum-based products (including kerosene, gasoline and diesel fuel) or any other harsh chemicals can damage pads.



Never use harsh chemicals on vacuum pad.

Many rubber conditioners can leave a hazardous film on pads.



Never use rubber conditioners on vacuum pad.

- 2) Prevent liquid from entering the vacuum system through the suction hole on the pad face.
- 3) Wipe the pad face clean, using a clean sponge or lint-free cloth to apply the cleanser.¹
- 4) Allow the pad to dry completely before using the lifter.

1..... A brush with bristles *that do not harm rubber* can help remove contaminants clinging to sealing edges. If these cleaning methods are not successful, contact WPG or an authorized dealer for assistance.

MAINTENANCE

TO REPLACE PAD INSERTS IN VPFS625 PADS

If the vacuum lifter has VPFS625 vacuum pads (#58383), replace its pad inserts (#49726):

Note: The Pad Repair Kit (#58387) also includes associated hardware. Instead of setting aside and reusing the existing hardware as directed below, use the hardware supplied with the kit.

- 1) Remove the lock nuts and washers that secure the top plate to the face plate of the pad assembly (fig. 1A). Make

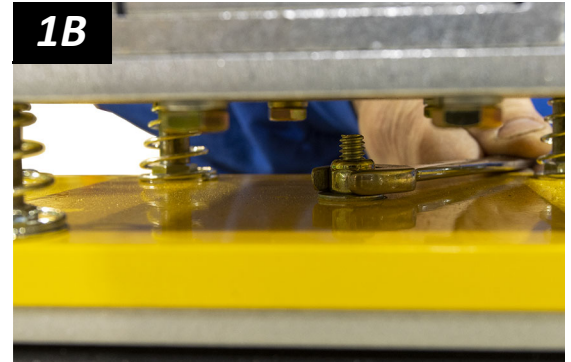

sure to remove the hardware underneath the pad mount, as well (fig. 1B).

Note: Set aside the removed hardware.

- 2) Remove the old pad insert from the pad's plates (figs. 2A-B).



Note: Do not remove the spacers from

the bottom plate (see arrow in fig. 2B).

Caution: If a pad insert does not easily separate from the plates, appropriate tools may be needed to complete this step. Take care to avoid damaging the plates.

If needed, use a paint scraper or similar tool to remove pad insert debris from the plates (figs. 2C-D).



MAINTENANCE

3) Clean and/or replace the filter screen (fig. 3A).

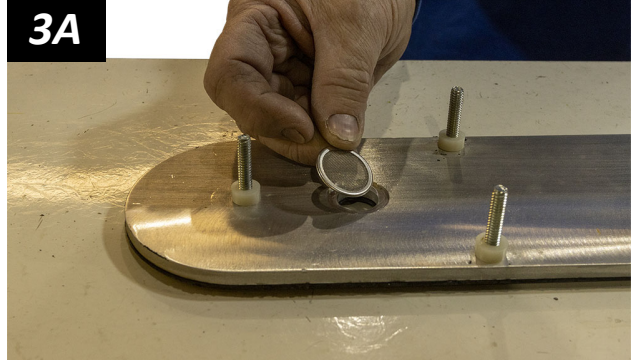

4) Inspect the new pad insert, to determine which side of the insert face has the smoother edge (circled in fig. 4A).

Note: The difference in the edge smoothness will be subtle.



5) Install the new pad insert on the bottom plate, making sure the smoother edge faces down (fig. 5A).

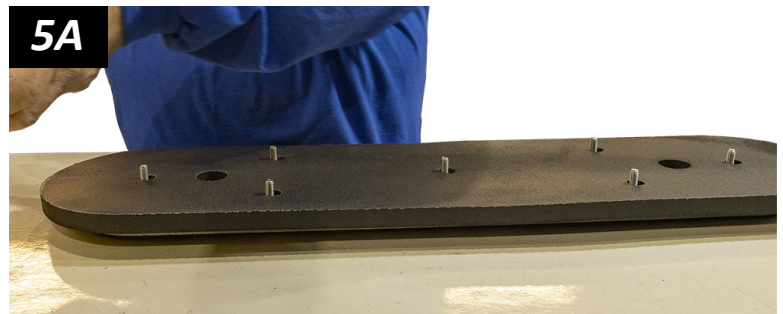

6) Applying pressure to the top plate, reinstall it and tighten hardware securely (fig. 6A).

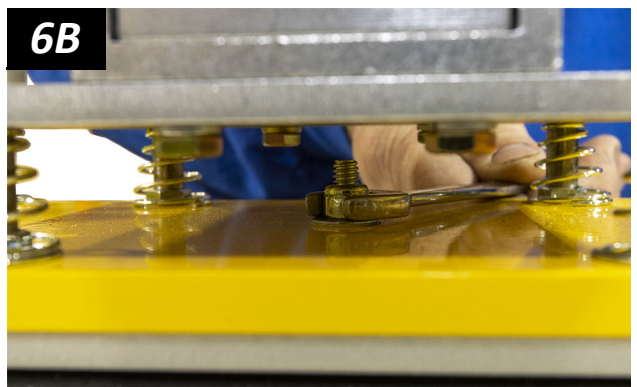
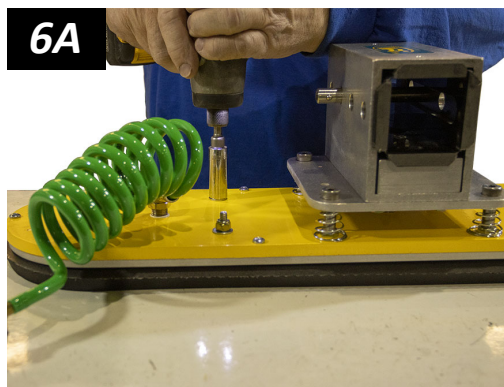

Make sure to securely install hardware underneath the pad mount, as well (fig. 6B).

Note: Replace worn nuts as needed.

MAINTENANCE

12-VOLT BATTERY RECHARGE¹

Charge the battery whenever the battery gauge shows reduced energy.² **Caution:** Make sure the lifter is powered down.

Identify the input voltage marked on the battery charger and plug it in to an appropriate power source.³



Make sure power source has ground fault circuit interrupter.

Press the “MODE” button to select “NORMAL” mode. Lights 1-4 indicate the charging level attained.⁴ When the battery is fully charged, light 4 (green) turns on and the charger switches to maintenance mode.

The battery should take no more than 8 hours to charge completely.⁵ After reaching level 3, the charger analyzes the battery condition. If the battery needs to be replaced, the charger's red error light (!) turns on (see “REPLACEMENT PARTS”).

Before you return the lifter to service, recheck the battery as previously directed.

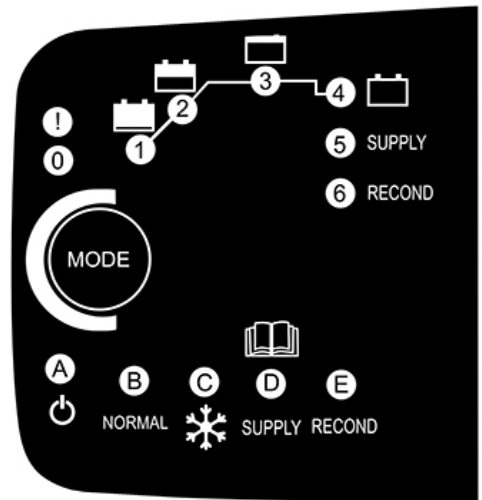

- 1..... You may use a battery charger other than the one supplied, provided it is designed for 12-volt DC, AGM type, lead-acid batteries. Disconnect the battery from the vacuum generating system before charging.
- 2..... To maximize the battery's lifespan, charge it promptly after each use.
- 3..... Any external power supply must conform to all applicable local codes. The lifter is not intended for use while the charger is connected to AC power.
- 4..... If none of the charging level lights turns on, the battery connection or the battery itself may be faulty. If the red error light (!) turns on immediately, the battery leads may be reversed or the charger terminals may be short-circuited; once the problem has been corrected, the charger should function normally. The red error light can indicate other problems, depending on the mode selected and level of charging; if necessary, contact WPG for assistance.
- 5..... The charger automatically reduces the charging rate when the battery is fully charged.

MAINTENANCE

NOTIFICATION BUZZER BATTERY REPLACEMENT

- 1) Power down the lifter.
- 2) Release the buzzer battery holder by pressing inward and sideward in the direction marked on the holder.
- 3) Slide the battery tray out (fig. 3A).
- 4) Install a new 9-volt battery according to the polarity markings.
- 5) Slide the battery tray back into position.
- 6) Power up the lifter again, to test the new battery.



MAINTENANCE

INTELLI-GRIP® DIAGNOSTIC CODES

Refer to the following table when a diagnostic code appears on the LCD screen. Codes are listed in alphanumeric order. If the Explanations/Directions do not resolve the issue, contact qualified service personnel. All relevant parts are listed in “REPLACEMENT PARTS”.

Key: = buzzer sounds = buzzer sounds continuously = strobe light flashes

Code	On-Screen Message	Buzzer Pattern	Strobe Light Activity	Explanations/Directions
B00	“Low 12V Battery (#)”	1 chirp every 2 seconds	(none)	Charge 12V <u>battery</u> or, if necessary, replace it (see “ 12-VOLT BATTERY RECHARGE ”). Cold battery may need to be warmed and/or charged more often.
B01	“Lockout (low 12V battery) (#)”	continuous	(none)	Once “Power Save” mode is activated, “attach” and “release” functions are prevented because 12V <u>battery</u> energy is insufficient. Charge battery before next lift (see “ 12-VOLT BATTERY RECHARGE ”).
B02	“Replace 12V battery?”	1 chirp per minute	(none)	Check condition of 12V <u>battery</u> (see “ Checking the 12-Volt Battery ” and “ 12-VOLT BATTERY RECHARGE ”). Since cold battery may prematurely activate this notification, warm battery and retest when appropriate. Replace battery as needed. Note: This notification can be activated in error if <u>battery charger</u> is plugged into power source while lifter is powered up. If so, power down lifter, disconnect charger from power source, and power up again. If code persists, check battery condition as directed above.
B03	“Charge 12V battery soon”	1 chirp per minute	(none)	Charge 12-volt <u>battery</u> (see “ 12-VOLT BATTERY RECHARGE ”).
B09	“Replace 9V battery?”	1 chirp per minute	(none)	Replace 9V battery for <u>notification buzzer</u> as needed (see “ NOTIFICATION BUZZER BATTERY REPLACEMENT ”).
C00	“Fail-safe on module”	continuous	on	Fail-safe mode has been activated, to prevent potential injury. Service is required.
C011	“Communication failure, module 1”	fast chirp	(none)	If code does not clear automatically, service is required.
C021	“Internal error, module 1”	continuous	(none)	If code does not clear automatically, service is required.
C04	“Module revision not compatible”	1 chirp every 2 seconds	(none)	Make sure lifter is used within Operating Temperatures (see “ SPECIFICATIONS ”). Then power lifter down and up again. If code persists, service is required.
C05	“Module revision lockout”	continuous (while button is held)	(none)	Once “Power Save” mode is activated, “attach” and “release” functions are prevented in connection with Code C04. Service is required.

MAINTENANCE

Code	On-Screen Message	Buzzer Pattern	Strobe Light Activity	Explanations/Directions
C06	"Control head not compatible"	1 chirp every 2 seconds	(none)	Incompatible version of software was installed or <u>Intelli-Grip® control unit</u> has failed. Service is required.
C07	"Control head revision lockout"	continuous (while button is held)	(none)	Once "Power Save" mode is activated, "attach" and "release" functions are prevented in connection with Code C06. Service is required.
E00 E01 E02 E03 E04	"EEPROM error, cell #"	occasional chirp	(none)	Memory error detected. Service is required.
I000	"I2C error (#)"	single chirp	(none)	If code does not clear automatically, service is required.
N00	"Automatic attach"	(none)	(none)	System activated "attach" mode as precaution because significant vacuum was detected, even though no one initiated "attach" function. No corrective action is necessary. However, when appropriate, qualified service personnel can adjust sensitivity to vacuum detection.
N01	"Automatic attach"	(none)	(none)	System activated "attach" mode as precaution because load did not release completely. No corrective action is necessary. However, when appropriate, qualified service personnel can adjust sensitivity to vacuum detection.
N02	"Automatic attach"	(none)	(none)	System activated "attach" mode as precaution when lifter was powered up because power was previously lost while load was attached. No corrective action is necessary.
N03	"Unable to turn module power off"	1 chirp every 2 seconds	(none)	Remove 9V battery. Disconnect connector between 12V <u>battery</u> and vacuum generating system. Charge battery completely (see " 12-VOLT BATTERY RECHARGE "). Then reconnect battery and try to power down again. If code persists, disconnect connector. Service is required.
N04	"Failed to turn controls power off"	1 chirp every 2 seconds	(none)	Remove 9V battery. Disconnect connector between 12V <u>battery</u> and vacuum generating system. Charge battery completely (see " 12-VOLT BATTERY RECHARGE "). Then reconnect battery and try to power down again. If code persists, disconnect connector. Service is required.
N05	"Unable to turn module power on"	1 chirp every 2 seconds	(none)	Charge 12V <u>battery</u> (see " 12-VOLT BATTERY RECHARGE "). Then power lifter up again. If code persists, service is required.
N06	"Power-down reminder"	2 chirps	on briefly	Power down to prevent 12V <u>battery</u> discharge when lifter is not in use.
N07	"Auto power-down disabled"	(none)	(none)	Automatic power-down is prevented. Power lifter down and up again. If code persists, service is required.
N08	"powering down in # seconds"	1 chirp per minute	(none)	Lifter will automatically power down in number of seconds shown. Press any button to cancel action.
N10	"App-support hardware fault"	(none)	(none)	Fault is detected in hardware that enables communication with mobile app. Power lifter down and up again. If code persists, service is required.

← MAINTENANCE →

Code	On-Screen Message	Buzzer Pattern	Strobe Light Activity	Explanations/Directions
U00	"WARNING! Is load attached?"	fast chirp	on	Attempt was made to power down lifter while load was still detected. Lower load onto stable support and release load <i>before</i> powering down lifter.
U01	"Also hold [Fn] to power down"	(none)	(none)	Hold " <u>function</u> " button and " <u>power</u> " button at same time to power down lifter.
U02	"Turn off? Let go of buttons"	(none)	(possible)	Use only " <u>function</u> " button and " <u>power</u> " button to power down lifter. Lifter cannot be powered down while any other button is pressed.
U03	"Timed release: # seconds"	1 chirp per button press	on	Timed release function is activated for number of seconds shown (see " TO RELEASE THE PADS FROM THE LOAD "). Press " <u>function</u> " button to cancel action or press " <u>attach</u> " button to override. No corrective action is necessary.
U04	"Also hold [Fn] to release"	(none)	(none)	Hold " <u>function</u> " button and " <u>release</u> " button at same time to release load.
U06	"Let go of [Fn] and Release"	(none)	on	Use only " <u>attach</u> " button to attach load. While " <u>attach</u> " button is pressed, lifter does not respond to pressing any other button. Release all buttons and press button(s) again to activate different function.
U08	"Menu not available in Attach"	(none)	(none)	Operator Menus cannot be accessed while lifter is attached to load.
U09	"Counterweight not retracted"	continuous	on	"Release" function is prevented because counterweight is not positioned correctly. Reposition counterweight as directed (see Counter-Balancer <i>OPERATING INSTRUCTIONS</i> , if necessary).
U10	"Use POWER button for Live Stats"	(none)	(none)	" <u>Power</u> " button (not " <u>function</u> " button) is now used to access Live Stats. No corrective action is necessary.
U11	"Testing battery - wait to attach"	(none)	(none)	"Attach" function is prevented because <u>battery</u> test is in progress. Wait until <u>vacuum pump</u> stops running and try again.
V000	"INSUFFICIENT VACUUM!"	continuous	on	Immediately lower load onto stable support until adequate vacuum can be obtained. Check load and <u>vacuum pads</u> for damage. Consult relevant topics in "ASSEMBLY", "OPERATION", "INSPECTIONS AND TESTS", and "MAINTENANCE".
V001 V002 V003 V004	"INSUFFICIENT VACUUM #!" (# indicates relevant vacuum circuit)	continuous	on	Immediately lower load onto stable support until adequate vacuum can be obtained in vacuum circuit indicated. Check load and <u>vacuum pads</u> for damage. Consult relevant topics in "ASSEMBLY", "OPERATION", "INSPECTIONS AND TESTS", and "MAINTENANCE". This code can be activated in connection with Code N00.
V011 V012 V013 V014 V015	"Vacuum decrease on circuit #" (# indicates relevant vacuum circuit)	3 chirps	(none)	Vacuum decreased at greater rate than expected in circuit(s) indicated. Possible causes include bouncing or landing load, as well as use on rough or porous loads and other sources of vacuum leaks. Consult relevant topics in "ASSEMBLY", "OPERATION", "INSPECTIONS AND TESTS", and "MAINTENANCE" to eliminate leaks when possible. When appropriate, qualified service personnel can adjust sensitivity to vacuum level reductions.

MAINTENANCE

Code	On-Screen Message	Buzzer Pattern	Strobe Light Activity	Explanations/Directions
V020	"Vacuum not increasing normally"	1 chirp every 2 seconds	on	Although lifter began to attach, vacuum level did not increase at normal rate. Make sure all <u>vacuum pads</u> seal securely (see " Sealing the Pads on the Load " and " Reading the Vacuum Gauges "). This Code can be activated by use at high elevation. If so, contact WPG for directions.
V03A V03B	"Pump running excessively"	1 chirp every 2 seconds	(none)	<u>Vacuum pump</u> is running more often than normal. Likely causes include significant vacuum leak or difficulty achieving minimum vacuum level due to high elevation. In case of suspected leak, check for fault(s) in vacuum system. See relevant topics in "ASSEMBLY," "OPERATION" "INSPECTIONS AND TESTS", and "MAINTENANCE". In case of high elevation, contact WPG for directions.
V040	"Lockout (vacuum sensor error)"	continuous	(none)	Once "Power Save" mode is activated, "attach" and "release" functions are prevented due to a <u>vacuum sensor</u> malfunction. Make sure sensor connectors are attached correctly.
V050	"DANGER! INSUFFICIENT VACUUM!"	continuous	on	Vacuum levels in BOTH circuits are insufficient for lifting. Keep everyone away from suspended load until it can be safely lowered to a stable support. Service is required.
V081 V082 V083 V084	"Sensor # error (low)" (# indicates relevant vacuum circuit)	continuous in "attach" mode; 1 chirp every minute in "power save" mode	(none)	<u>Vacuum sensor</u> malfunction in vacuum circuit indicated. Make sure sensor connector is attached correctly.
V091 V092 V093 V094	"Sensor # error (high)" (# indicates relevant vacuum circuit)	continuous in "attach" mode; 1 chirp every minute in "power save" mode	(none)	<u>Vacuum sensor</u> malfunction in vacuum circuit indicated. Make sure sensor connector is attached correctly.

REPLACEMENT PARTS

Stock No.	Description	Qty.
93022	Quick Connector – 1/8 FNPT – Male End – w/45° Barb	12
65442CA	Vacuum Hose – 0.160" ID x 1/4" OD – Red	*
65442AM	Vacuum Hose – 0.245" ID x 3/8" OD x 48" Length – Coiled – Green	6
65441	Vacuum Hose – 0.245" ID x 3/8" OD x 48" Length – Coiled – Red	6
65440	Vacuum Hose – 0.245" ID x 3/8" OD – Red	*
65439AM	Vacuum Hose – 3/32" ID x 5/32" OD – Red	*
65437	Vacuum Hose – 0.245" ID x 3/8" OD – Green	*
65429BM	Vacuum Hose – 0.160" ID x 1/4" OD – Green	*
65025	Pad Spring – Tapered Type	32
59906	Remote Control System Retrofit Kit (optional)	1
59397	Pad Frame Extension Kit for Roof Panel Installation (optional)	1
58387	Vacuum Pad Repair Kit	8
58383	Vacuum Pad – Model VPFS625 – 6" x 25" [15 cm x 64 cm] – w/Replaceable Sealing Insert	8
58380PF	Vacuum Pad Replacement Face	8
49726	Vacuum Pad Insert – Model VIFS625 / 6" x 25" [15 cm x 64 cm]	8
36106	Service Manual – 12 V DC – Dual Vacuum System – Intelli-Grip®	1
29354	Pad Cover	8
16056	Quick Connector – 1/8 FNPT – Female End	8
15791	Control Handle	2
15630	Pad Filter Screen – Large	8
15310AM	Pad Fitting – Push-In Swivel Elbow – 1/4 MNPT to 3/8" OD Hose Size	8
13534	Cotterless Hitch Pin – 1/2" x 4"	4
13532	Cotterless Hitch Pin – 1/2" x 3-3/8"	8
10906AM	Shoulder Bolt – Socket Head – 3/8" x 1/2" x 5/16-18 Thread	32

* – Length as required; sold by the inch (approx 2.5 cm).

See **SERVICE MANUAL #36106** for additional parts.

**SERVICE ONLY WITH IDENTICAL REPLACEMENT PARTS,
AVAILABLE AT WPG.COM OR THROUGH AN AUTHORIZED WPG DEALER**

REGISTRATION AND LIMITED WARRANTY

TO REGISTER THIS WPG PRODUCT

Go to the [PRODUCT REGISTRATION](#) page at [wpg.com](#) and complete the form. Registration keeps you advised of important updates and notifications, and simplifies inquiries to WPG regarding your product. Registration is **not** required to activate your Limited Warranty (see next section).

ABOUT THE LIMITED WARRANTY

Note: Read the [WARRANTY RETURN FORM](#) at [wpg.com](#) for important details about the Limited Warranty.

Wood's Powr-Grip® (WPG) products are warranted to be free from defects in manufacturing and materials for 1 year from the date of purchase.

If a problem develops during the warranty period, follow the instructions below to obtain warranty service. If inspection shows that the product has a defect, WPG will repair or replace the product without charge.



Obtaining Warranty Service or Repair Service

For customers in the U.S. and Canada: Go to the [EXCHANGES, REPAIRS, & WARRANTIES](#) page at [wpg.com](#) and click the applicable link. Alternatively, you may contact the WPG Technical Service Department (see contact information below).

For customers in all other localities: Contact the WPG Technical Service Department (see contact information below) or your dealer for assistance.

ADDRESS	EMAIL	PHONE
Wood's Powr-Grip Co., Inc. 908 West Main St. Laurel, MT USA 59044	contactus@wpg.com	(1) 800-548-7341 (1) 406-628-8231

INTENDED FOR USE BY QUALIFIED SERVICE PERSONNEL

ENGINEERING DRAWINGS

 READ AND UNDERSTAND BEFORE ROUTING,
WIRING AND/OR ASSEMBLING



908 W. Main • P.O. Box 368

Laurel, MT USA 59044

(1) 800-548-7341 • (1) 406-628-8231

www.wpg.com

**MANUAL TILTER, DC-VOLTAGE
WITH INTELLI-GRIP® TECHNOLOGY**
(Available with REMOTE CONTROL SYSTEM)

Model numbers: MTEX4625DC3, MTEX8625DC3

FILE DIRECTORY: 2013090103.00
PROJECT RD00500A-W01 [A-W01]

THIS DRAWING IS THE PROPERTY OF WOOD'S POWR-GRIP CO., INC. LAUREL, MONTANA U.S.A.
IT IS LOANED WITH THE UNDERSTANDING THAT NEITHER IT NOR ANY INFORMATION CONTAINED THEREIN WILL BE COPIED, PUBLISHED OR TRANSMITTED TO OTHERS WITHOUT EXPRESS WRITTEN PERMISSION.



DC3 DESIGN REVIEW

N/A
PUMP COVER WIRING SCHEMATIC
RD00500A-W01 [A-W01]

SIZE: A	SCALE: NONE	REVISION: 01.A	VER 01.A	ECN NUMBER: 10/27/2021	ECN DATE: 10/27/2021	MAP	EST. WEIGHT: N/A
---------	-------------	----------------	----------	------------------------	----------------------	-----	------------------

WIRE LEGEND: CONTROLLED BY WIRING SYMBOLS DRAWING EXCEPT AS NOTED AND BELOW.
LINE STYLES AND WIDTHS FOR WIRE UNLESS NOTED OTHERWISE:

.....	24AWG	22AWG	20AWG	N/A
	18AWG	16AWG	14AWG	N/A

PRODUCT MANAGER: MARTY P.
DATE: 07/27/2020
CHECKED: MAP
APPROVED:

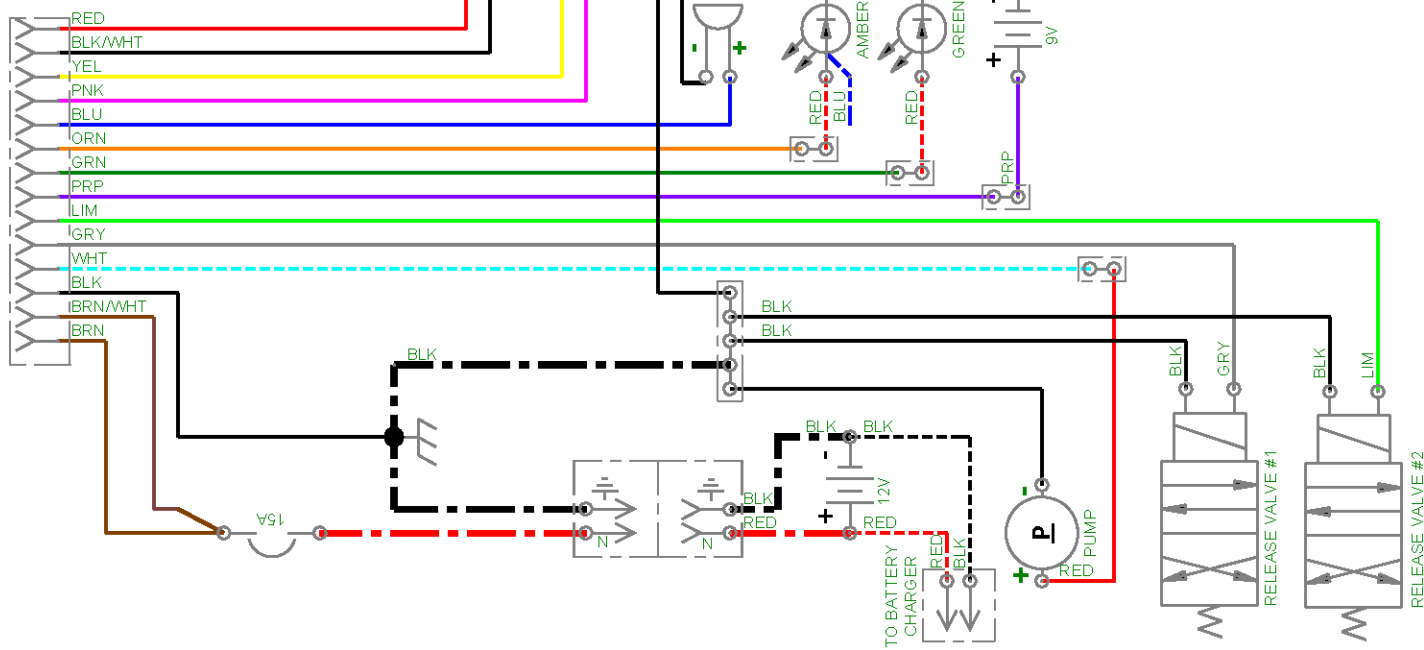

TYPE: STANDARD

WIRE LEGEND: CONTROLLED BY WIRING SYMBOLS DRAWING EXCEPT AS NOTED AND BELOW.

LINE STYLES AND WIDTHS FOR WIRE UNLESS NOTED OTHERWISE.

N/A 22 AWG --- N/A --- 18 AWG

PRODUCT MANAGER: GARY B.

CHECKED: CR

APPROVED: Cmsr

RADIO REMOTE CONTROL

MRT4-DC3

5-PIN DC3 RADIO RECEIVER WIRING SCHEMATIC, FCC & CE

D713K-W01 [K-W01]

SIZE: A	SCALE: NONE	REVISION: 04.A	ECN NUMBER: 4897	ECN DATE: 05/21/2020	ECN BY: CCH	EST. WEIGHT: N/A
---------	-------------	----------------	------------------	----------------------	-------------	------------------

