

KEEP FOR FUTURE REFERENCE

SERVICE MANUAL



908 W. Main • P.O. Box 368
Laurel, MT USA 59044
800-548-7341 (phone)
406-628-8231 (phone)
406-628-8354 (fax)
www.WPG.com

 **INTENDED FOR USE BY SKILLED
TECHNICAL PROFESSIONALS • READ
AND UNDERSTAND BEFORE SERVICING**



**1 SCFM
NOMINAL AIRFLOW
DUAL VACUUM SYSTEM
DC-VOLTAGE POWER SYSTEM
WITH MANUAL VALVE**

Stock number: 36111



TABLE OF CONTENTS

BEFORE SERVICING LIFTER	2
SERVICE SCHEDULE	2
SERVICE FEATURES	3
SERVICE PROCEDURES.....	4
AIR FILTER MAINTENANCE – T TYPE.....	4
Filter Service Procedures	4
VACUUM PUMP MAINTENANCE – MODEL DV1032102	5
Replacing the Diaphragm.....	5
Replacing the Head Assembly.....	5
VACUUM SWITCH ADJUSTMENT (WITH RED WARNING LIGHT)	6
REPLACEMENT PARTS.....	7

BEFORE SERVICING LIFTER



Disconnect battery when necessary to prevent electrical shock or other risks.

Whenever necessary, disconnect the electrical connectors for the battery (figs. 1A-C).

Service personnel must read and understand the lifter's *OPERATING INSTRUCTIONS* – especially the “INSPECTIONS AND TESTS” and “MAINTENANCE” sections – before servicing the vacuum lifter. Many of the following discussions assume knowledge of the *OPERATING INSTRUCTIONS*.

Note: Wiring and/or hose-routing diagrams are provided in the OPERATING INSTRUCTIONS, for reference when servicing or troubleshooting the lifter.

SERVICE SCHEDULE

Service must be performed whenever a deficiency is indicated by routine inspections or tests. Follow the “INSPECTIONS AND TESTS” section of the lifter's *OPERATING INSTRUCTIONS*.

Any service warranted must be performed before resuming normal operation of the lifter.

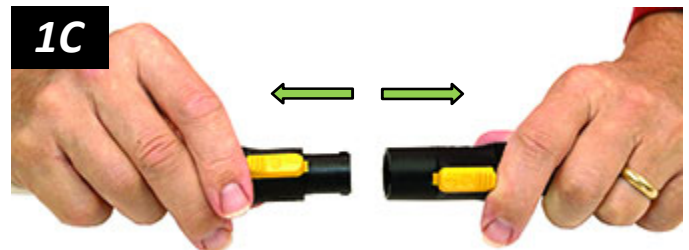
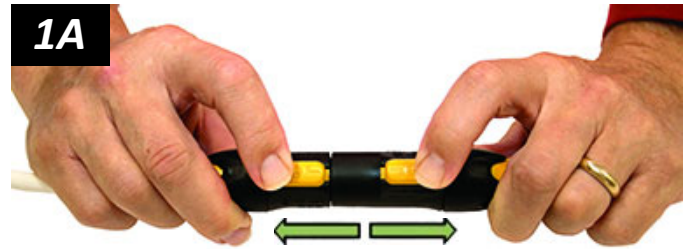

SERVICE FEATURES

Components shown here are underlined> on their first appearance in each section to follow.

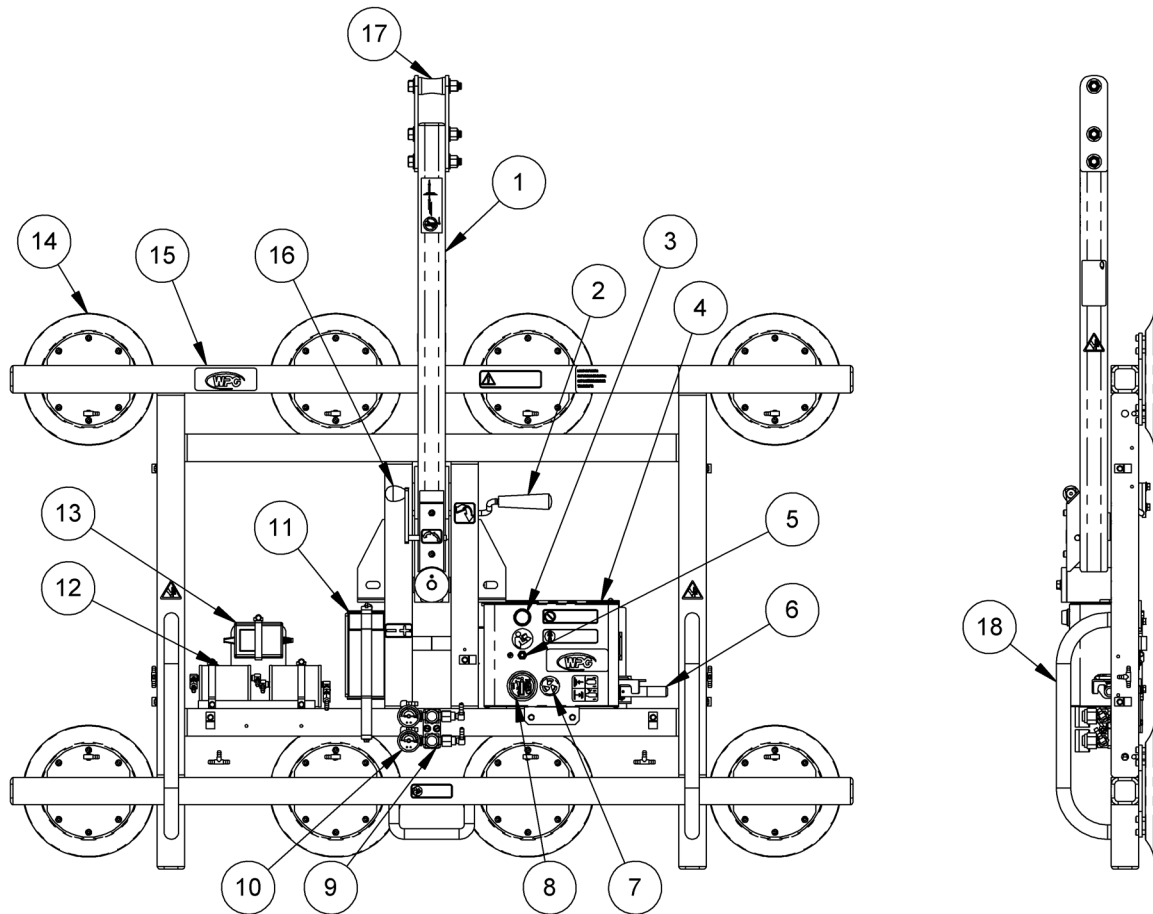

- | | | | | | |
|----|------------------------------------------------|----|---------------------|----|--------------------------|
| 1 | LIFT BAR | 2 | TILT RELEASE LEVER | 3 | LOW VACUUM WARNING LIGHT |
| 4 | Enclosure with VACUUM PUMP and VACUUM SWITCHES | 5 | BATTERY TEST BUTTON | 6 | VALVE HANDLE |
| 7 | LOW VACUUM WARNING BUZZER | 8 | BATTERY GAUGE | 9 | AIR FILTERS |
| 10 | VACUUM GAUGES | 11 | BATTERY | 12 | VACUUM RESERVE TANKS |
| 13 | BATTERY CHARGER | 14 | VACUUM PAD | 15 | PAD FRAME |
| 16 | ROTATION RELEASE LEVER | 17 | LIFT POINT | 18 | CONTROL HANDLE |

Note: A standard PPHL89DCO-DVS is shown.¹

1..... Some components may not be relevant or they may have a different location, depending on the lifter in question.

SERVICE PROCEDURES

AIR FILTER MAINTENANCE – T TYPE



Inspect each air filter regularly and service when necessary.

Immediately remove liquid or other contaminants found in the filter bowl (item 1 in fig. 1A). Clean or replace the element whenever:

- It has an overall dirty appearance.
- There is a noticeable increase in the time required to attain full vacuum.

Filter Service Procedures

- 1) Unscrew the bowl (item 1 in fig. 1A) from the body (item 2) of the air filter.

Note: To protect air-line fittings from damage, hold the body while turning the bowl.

*Note: Do **not** attempt to remove the snap ring on the bowl.*

- 2) Carefully remove the element (item 3) and gasket (item 4) from the bowl.

- 3) Remove liquid or other contaminants from the bowl.

- 4) Clean the bowl, element and gasket with mild soap and water, using compressed air to remove liquid or other contaminants.

Caution: Do not use any other cleaning agents.

- 5) Replace the element (**#16103**) or the gasket (**#16133**), if it cannot be cleaned adequately.

- 6) Install the new or cleaned element in the body.

- 7) Lubricate the gasket using a mineral base oil or grease, or silicone, and install the gasket.

- 8) Screw the bowl back onto the body, and tighten it snugly with a wrench.

Caution: Do not contaminate the element with lubricant from the gasket.

- 9) Perform the “Vacuum Test” to be certain the air filter does not leak (see “INSPECTIONS AND TESTS: TESTING” in the lifter's *OPERATING INSTRUCTIONS*).

Note: Repeat this procedure for any other filter of the same type.

1A

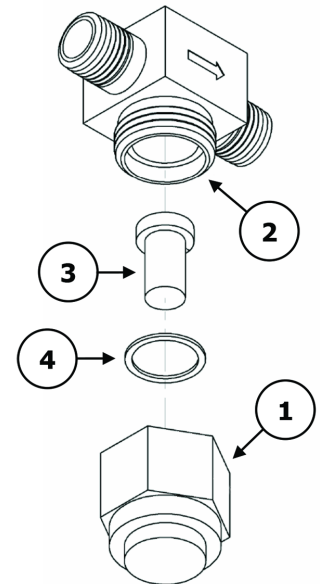

SERVICE PROCEDURES

VACUUM PUMP MAINTENANCE – MODEL DV1032102



Disconnect power source before proceeding.

If the vacuum pump takes too long to attain full vacuum, replace the diaphragm or the head assembly as necessary to obtain acceptable pump performance (fig. 1A). Then perform the “Vacuum Test” (see “INSPECTIONS AND TESTS: TESTING” in the lifter's *OPERATING INSTRUCTIONS*).

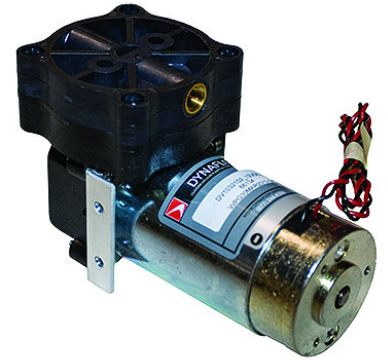

Caution: Do not overtighten the head screws, because this may damage the pump body's threads.

Replacing the Diaphragm

- 1) Remove the four head screws (item 1 in fig. 1A) and lock washers (item 2), and remove the head assembly (item 3).
- 2) Remove the diaphragm retaining screw (item 4), diaphragm (item 5), rubber O-ring (item 6) and flat washer (item 7).
- 3) Replace the flat washer, rubber O-ring, diaphragm and diaphragm retaining screw.
- 4) Reverse these steps to reassemble the pump.

1A

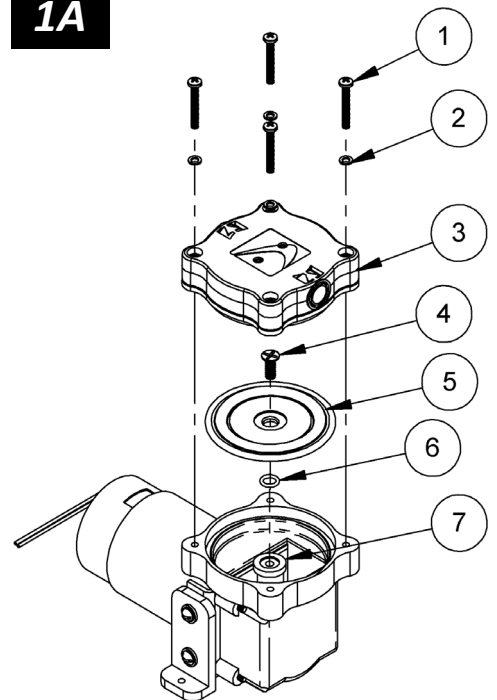

- 1 HEAD SCREW
- 2 LOCK WASHER
- 3 HEAD ASSEMBLY (#66197)
- 4 DIAPHRAGM RETAINING SCREW
- 5 DIAPHRAGM (#66197AM)
- 6 RUBBER O-RING
- 7 FLAT WASHER

Replacing the Head Assembly¹

- 1) Remove the hose fittings from the head assembly, and carefully clean the threads. Be sure to note the fitting locations for reassembly.
- 2) Remove the four head screws (item 1 in fig. 1A), lock washers (item 2) and head assembly (item 3).
- 3) Replace the head assembly (reverse *step 2*).
- 4) Reinstall the hose fittings, using an appropriate thread sealant.

1..... **Caution:** Depending on the product, the head assembly (3) may be rotated to an orientation different from the one shown. When removing the head assembly, always take note of its orientation and install it the same way during reassembly.

SERVICE PROCEDURES

VACUUM SWITCH ADJUSTMENT (WITH RED WARNING LIGHT)

The vacuum switch turns the vacuum pump on and off as needed to maintain sufficient vacuum for lifting the maximum load weight, as shown on the vacuum gauge (see “OPERATION”: To ATTACH THE PADS TO A LOAD: Reading the Vacuum Gauge” in the lifter’s *OPERATING INSTRUCTIONS*).¹

*Note: The red low vacuum warning light turns on and off along with the vacuum pump, to signal a vacuum loss.*²

If the switch is adjusted correctly, the pump turns off only *after* vacuum becomes sufficient for lifting; and turns on again *before* vacuum becomes insufficient for lifting.³ Adjust the vacuum switch when necessary:



Lifting capacity decreases whenever vacuum switch is adjusted to maintain lower vacuum level.

- 1) Use the 1/4" open-end wrench provided to turn the adjustment screw (circled in fig. 1A) about 1/6th turn at a time:

- To *increase* the vacuum level maintained by the lifter, turn the screw *counterclockwise* (fig. 1B).
- To *reduce* the vacuum level maintained by the lifter, turn the screw *clockwise* (fig. 1C).

- 2) Recheck pump activity in relation to the vacuum level.⁴ Continue to make incremental adjustments until the vacuum switch is functioning correctly.

1A



1B

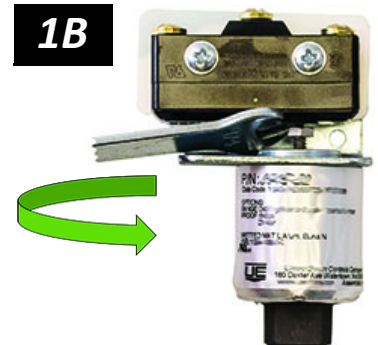

1C

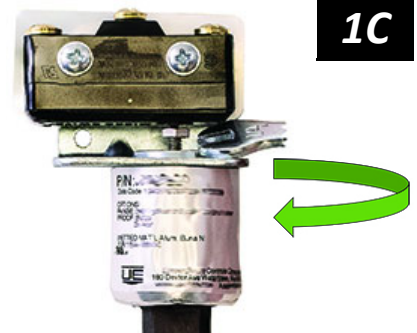

1..... Lifters with a dual vacuum system have 2 vacuum switches. For these lifters, each vacuum switch must be tested and adjusted individually.

2..... If the warning light does not turn on when the pump turns on, replace the bulb.

3..... In order to observe lifter functions while vacuum is decreasing, it may be necessary to create a controlled leak in the vacuum system.

4..... In order to test the adjustment accurately, release the vacuum pads completely before reattaching them to a test surface.

REPLACEMENT PARTS

Stock No.	Description	Qty.
93220	Vacuum Pump – Diaphragm Type – 1-SCFM – 12 V DC	1
93217	Vacuum Control Valve w/Handle and Fittings – Dual Vacuum System	1
66197AM	Pump Diaphragm Kit	1
66197	Pump Head Assembly	1
65211	Check Valve – 1/8 NPT	1
64752	Audio Alarm – 5-15 V DC – Panel Mount (for optional low vacuum warning buzzer)	1
64706EU	Battery Charger – 1.0 Amp – 240 V AC	1
64702US	Battery Charger – 1.0 Amp – 100 / 120 V AC	1
64664	Battery – 12 V DC – 7 Amp-Hours	1
64590	Battery Gauge	1
64460	Circuit Breaker – 15 A	1
64283	Bulb – 13 V – Bayonet (for low vacuum warning light)	1
64251	Red Indicator Light – 12 V DC (aka, low vacuum warning light)	1
64236	Vacuum Switch – 1/4 NPT	2
64230	Roller-Lever Switch	1
64200	Push-Button Switch (for battery test button)	1
54392NC	Battery Connector – Twin Lead	1
54390NC	Power Lead	1
20270	1/4" Open-End Wrench (for adjusting vacuum switch)	1
16133	Filter Element Kit – T Type	2
16103	Filter Gasket Kit – T Type	2
15911	Vacuum Gauge – 1/8 NPT – CBM Type	2

See lifter's **OPERATING INSTRUCTIONS** for additional parts.

**SERVICE ONLY WITH IDENTICAL REPLACEMENT PARTS,
AVAILABLE AT WPG.COM OR THROUGH AN AUTHORIZED WPG DEALER**